

Calibration Verification Kit (CVK-3TGT)

-for all Exergen TAT-2000, TAT-2000C, TAT-5000 and
TAT-5000S medical thermometers

What is the purpose of a calibration verification kit?

It allows the calibration of any Exergen TAT-2000, TAT-2000C, TAT-5000 or TAT-5000S series thermometer to be verified in the hospital, on nursing floors, or in the field, conveniently, quickly, and accurately.

Why is a CVK necessary?

Calibration verification is a commonly required part of routine quality assurance programs, and also is used if a question is raised about the accuracy of a particular thermometer. Actual recalibration of an Exergen thermometer is never required unless it has been physically damaged or experiences component failure, in which case the calibration verification test identifies the problem device, which then is returned to the factory for repair.

What is in the CVK-3TGT ?

A special TAT-5000S Certified Master (CM) reference thermometer of the same calibration type (Arterial or Oral) in use by the institution, 3 portable hand-held reference blackbodies, 3 AC plug-in adapter for long term use, 3 9-volt alkaline batteries for portable use, and a rugged storage case.

Who uses the CVK?

The main users are biomedical/clinical engineering, blood donor and pheresis units (in the United States, blood donor and pheresis units are required by the American Association of Blood Banks to verify thermometers on a daily basis), and many nursing units where accurate temperature is critical such as hematology/oncology, and bone marrow and organ transplant units. Exergen thermometers can quickly be checked for calibration accuracy using the portable handheld blackbody and master thermometer.

How is the CVK ordered?

The order must include the serial number of any one of the TAT-5000 or TAT-5000S thermometers that will be verified. This identification assures an exact calibration match to the CM reference thermometer.

Does the master reference thermometer need calibration?

The calibration of the CM thermometer should be checked and factory re-certified yearly. This is indicated by the due date on the calibration sticker affixed to the CM thermometer. On or before the due date the CM thermometer should be returned to Exergen for re-certification. The Exergen part number for re-certification is 139000, the cost is \$75.



Calibration Verification Kit,
CVK-3TGT

P/N 129050 – Arterial

P/N 129051 – Oral

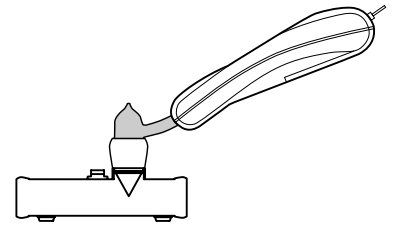

In Use with TAT-5000

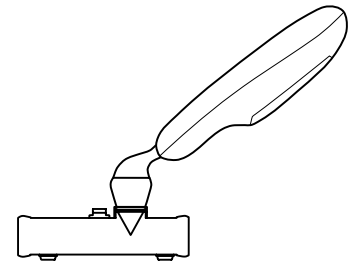

In Use with TAT-5000S

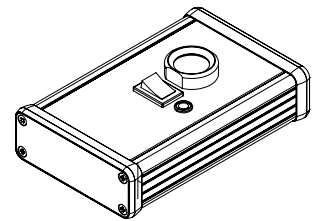

Handheld Blackbody

EXERGEN CORPORATION
400 Pleasant Street
Watertown, MA 02472
Phone 617.923.9900
Fax: 617-923-9911
www.exergen.com
Email: medical@exergen.com

Exergen Temporal Artery Thermometry

Calibration Verification Procedure

Suitable for All TAT-2000, TAT-2000C, TAT-5000 and TAT-5000S Models

All Exergen infrared thermometers are designed to permanently maintain their accuracy, and feature a patented hermetically-sealed optical system which protects the internal optical system against contamination by dirt, dust, moisture, and solvents.

Most reported problems are the result of a dirty lens. As infrared thermometers take an optical measurement, a dirty lens can result in a low reading. Cleaning the lens will result in an immediate return to normal calibration.

Normally, recalibration is never required unless the thermometer has been physically damaged or experiences component failure. Recalibration is done only at the factory, but calibration verification can be conveniently accomplished with a Calibration Verification Kit in biomedical engineering, and other areas requiring frequent accuracy verification of patient thermometry such as blood donor or pheresis units.

Calibration Verification Kit (CVK)

The CVK includes 3 portable blackbody heat generators providing a stable source of heat in a small cavity. These are used as target references to verify the calibration of any of Exergen's medical instruments against an Exergen Certified Master (CM) reference instrument, also included in the kit. The CM instrument must be of the same type calibration as the units to be tested (S/N label letters A or O need to match). If this is not the case, please contact Exergen. Use an Arterial CM (with a serial number beginning with 'A') to verify the accuracy of any TAT-2000 series thermometer.

Each verifier operates with either a 9-volt power supply plugged directly into a 90 to 264 VAC electrical outlet allowing its extended use, or for portable use on nursing floors, it can be completely powered by a 9-volt battery. A new alkaline battery can be expected to maintain the blackbody reference temperature up to five hours.

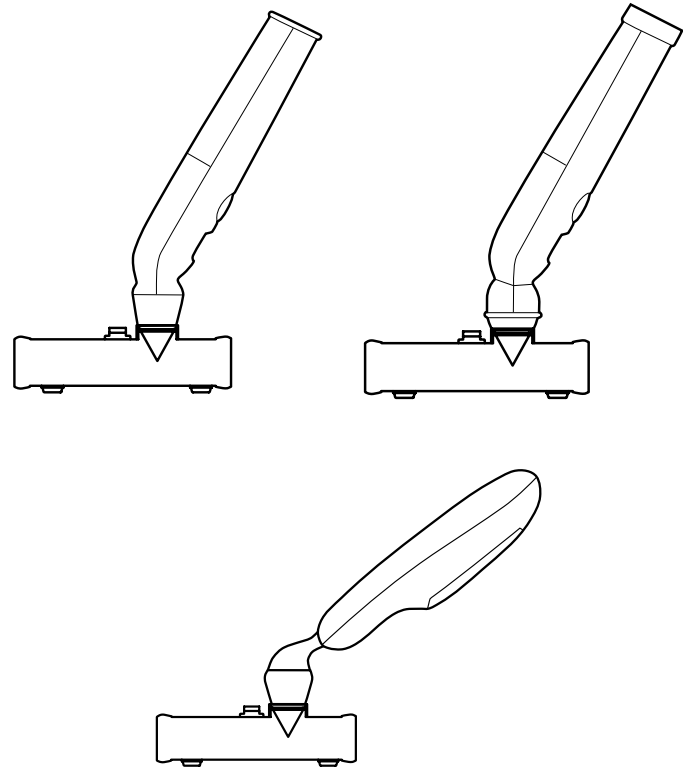

Figure 1. Portable black body is used to verify the calibration of any TAT-2000, TAT-2000C, TAT-5000 or TAT-5000S vs. a Certified Master, by comparison of readings.

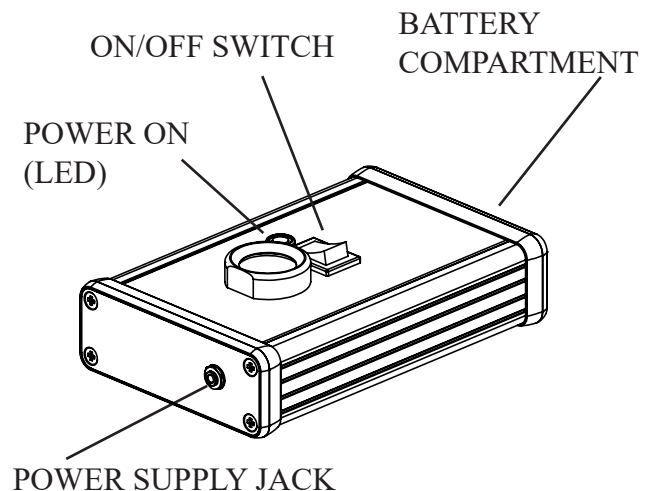

Figure 2. Model PBB-EC Portable Black-body Calibration Verifier

Exergen Temporal Artery Thermometry • Calibration Verification Procedure

Calibration Verification:

1. **Getting started.** Turn on each verifier device, making sure the LED is illuminated. If not, check the battery to assure it is installed correctly. If using the power supply, simply insert the plug into the power supply jack, and plug the power supply into any 90 to 264 VAC electrical outlet.

Check the serial numbers of both the Certified Master and the thermometer to be tested. Both should start with the letter 'A' (Arterial) or both with the letter 'O' (Oral) indicating that the calibration types are correct. If the serial numbers do not have matching letter prefix type codes, please contact Exergen. Use an Arterial CM to verify the accuracy of any TAT-2000 series thermometer.

2. **Allow devices to stabilize.** Once turned on, allow approximately 5 minutes for warm-up and stabilization time. If on battery power the LED should be on and bright. If it dims or goes out, the battery will no longer be able to maintain the stable reference temperature of the blackbody. Do not use the portable blackbody for comparative measurements if the LED is not on and bright.
3. **Allow both the Certified Master and instruments to be tested to acclimate to the same ambient temperature.** Allow to equilibrate to room temperature for at least 10 minutes. Allow extra time if the master thermometer or the thermometers to be verified have recently been brought from either very cold or very warm ambient temperature conditions.
4. **Assure lens is clean.** Make sure the lens at the tip of the probe of all instruments, including the Master Reference, is clean. To clean, use an alcohol dampened cotton tipped applicator (Q-tip) which is required to get directly on the lens.
5. **Do not use disposable covers when checking thermometer calibration with the CVK.**
6. **Conversion of Master thermometer from F to C:** The CM thermometer can be converted from Fahrenheit to Celsius and back by means of a switch, which is accessible in the battery compartment.

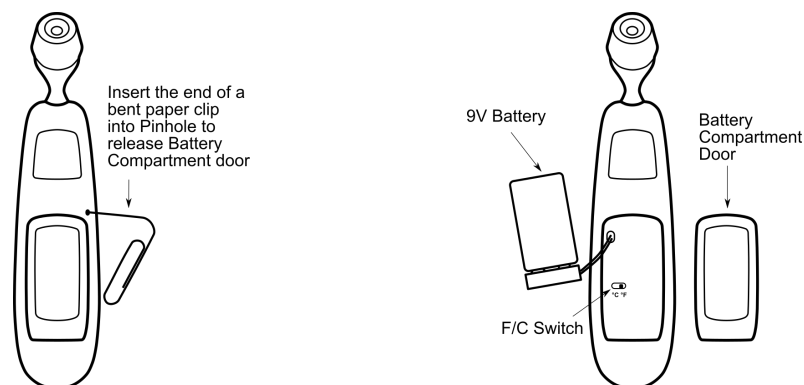

Exergen Temporal Artery Thermometry • Calibration Verification Procedure

7. **Measure the blackbody target** with both the master thermometer and thermometer being verified by pointing sensor head to the black heated target as indicated below.

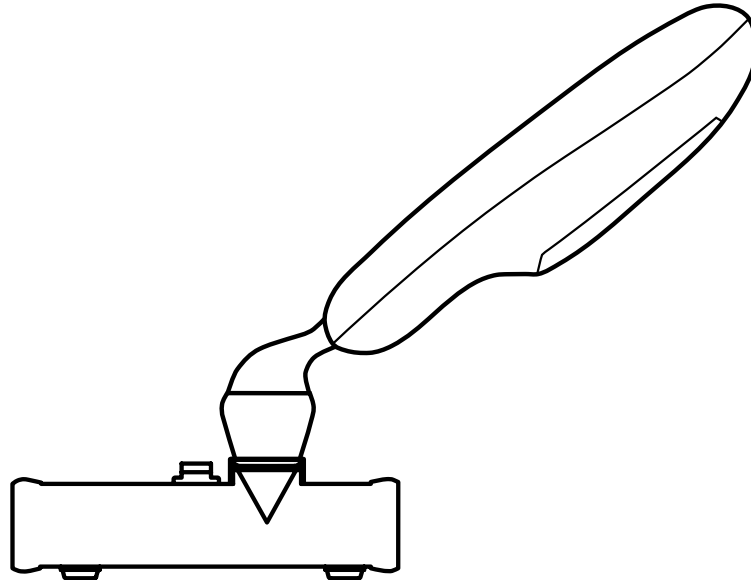

8. **Compare CM Reference Thermometer readings to test thermometer.** Alternately insert the CM thermometer and the thermometer being verified into the portable blackbody calibration verifier opening, comparing readings to the CM. One measurement reading using the CM thermometer should be adequate if multiple thermometers are to be verified. If larger quantities of thermometers are to be verified, it is recommended to measure the blackbody target with the CM thermometer once for every ten (approximately) thermometers being verified. This is done to prevent possible drift errors that could be induced into the CM thermometer.
9. **Accuracy Limits:** Comparison between CM and tested thermometer readings should be within $\pm 0.2^{\circ}\text{C}$ (0.4°F) for acceptable field limits for TAT-5000 and TAT-5000S series of professional thermometers, and within $\pm 0.3^{\circ}\text{C}$ (0.6°F) for acceptable field limits for TAT-2000 series of consumer thermometers. If not, repeat the process. In the event they still differ by more than the acceptable limits, call Exergen Corporation for replacement of the failed instrument.
10. **Heat Balance Awareness:** TAT-2000, TAT-2000C, TAT-5000 and TAT-5000S models employ the patented arterial heat balance method to adjust to their surrounding ambient temperature for precise, absolute accuracy. If left sitting on the heat well, they will assume the warmer temperature of the well, and thus will be at a different ambient than the instrument being tested (assuming it is at room temperature), and this could make a difference in the comparison of displayed temperatures.
11. **Reminder:** Comparisons between the CM and the instrument being tested should always be conducted under the same ambient temperature conditions.

Verifier Specifications:

- Power Source: 9-volt alkaline battery, or 9-volt power supply with adapter blades options for North America, Europe, the United Kingdom, Australia and China.
- Battery Life: approximately 5 hr.
- Low Voltage Indicator: red LED shuts off when battery voltage drops below ~5.4 volts. Blackbody target temperature is not stable for comparative measurements in this condition.
- Temperature: body temperature range 36 - 40°C (97 - 104°F).
- Cleaning: wipe down with alcohol or mild cleaning solution; do not immerse in any liquid.
- Recertification: Certification is for one year. Please call Exergen to arrange for recertification.

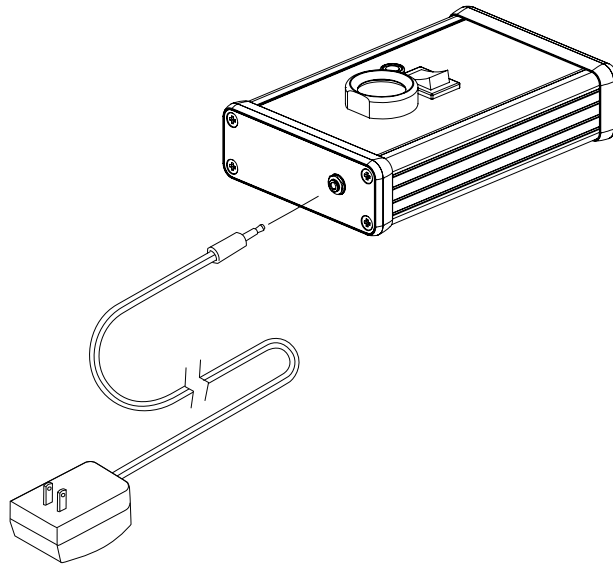

Figure 3. Power supply for PBB-1

If you have any questions about the calibration or operation of the Exergen Infrared Thermometers, please email medical@exergen.com, or call Exergen Medical Division.