

Increasing Production Speeds via Heat Balance Control With IR Sensing

**From
Fundamentals
to Frontiers**



Increasing Production Speeds via IR -Controlled Heat Balance



EXERGEN
CORPORATION

Speed Increase Stages

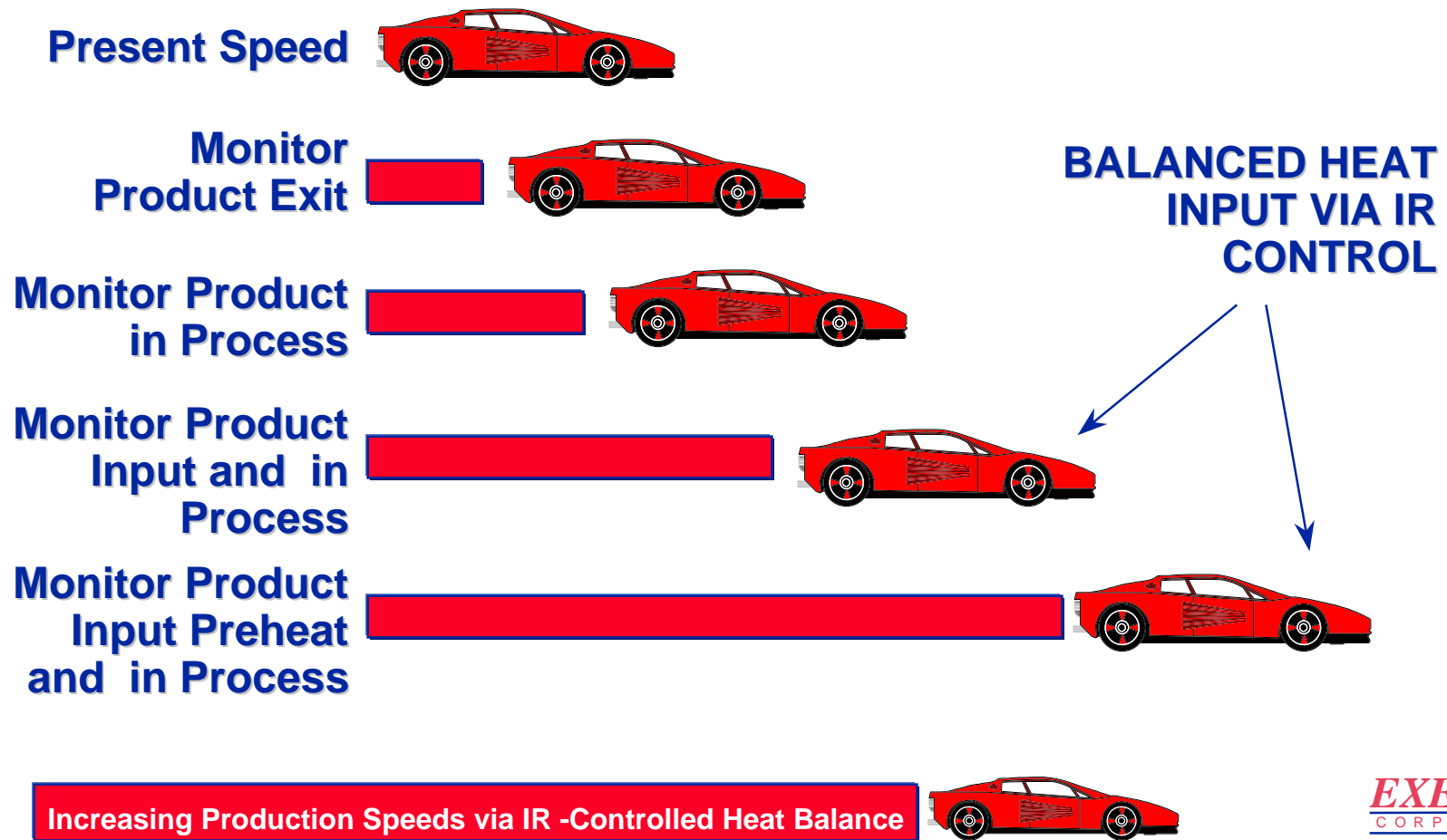

Speed Boost Equation

- **General Equation for Non-Contact IR Temperature Monitoring of Internal Temperatures of Moving Materials is Combined with Surface Temperature**
- **Leads to Uniform Material Temperature When Controlled via the *Speed Boost Equation***
- **Which Forces the Control System to Apply Heat at an Optimally *Balanced* Rate**

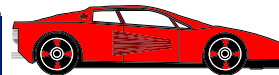

Speed Boost Equation

- General Equation Reduces to:

$$\frac{V_{new}}{V_{old}} = \frac{(\overline{\Delta T})_{new}}{(\overline{\Delta T})_{old}}, \quad \text{where } \overline{\Delta T} = \frac{T_{\infty} - T_s}{T_s - T_o}$$

Thermal Input (oven,
dryer, rolls, etc.)

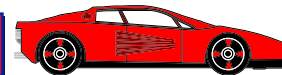
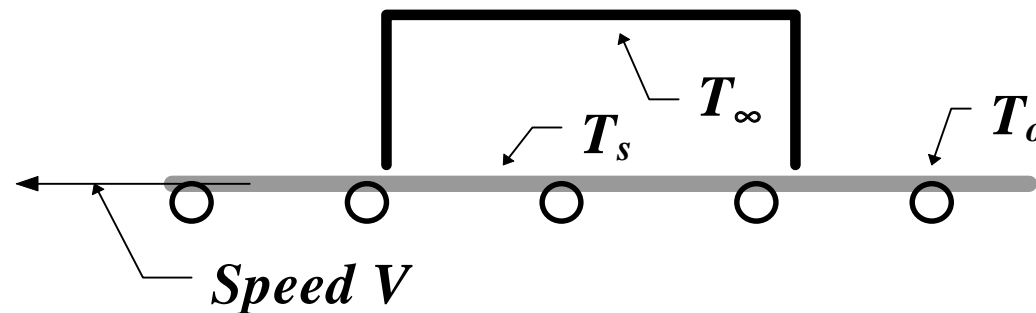

Speed Boost Equation

$$\frac{V_{new}}{V_{old}} = \frac{(\overline{\Delta T})_{new}}{(\overline{\Delta T})_{old}}, \quad \text{where } \overline{\Delta T} = \frac{T_{\infty} - T_s}{T_s - T_o}$$

- Above Can Be a Simplified Control Algorithm

$$T_{\infty} = (\overline{\Delta T} + 1)(T_s) - (\overline{\Delta T})(T_o)$$

Heat Source Temperature

Control Loop Gain

Product Input

Product Surface - setpoint

- Keep Equation Balanced to Within a Few % to Avoid Non-Uniformity in Material Temperature

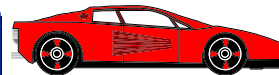

Example Speed Boost: Laminating

- Existing Set-up:

$$T_{\infty} = 105 \text{ C}$$

$$T_s = 85 \text{ C}$$

$$T_o = 25 \text{ C}$$

- New Set-up:

$$T_{\infty} = 120 \text{ C}$$

$$T_s = 85 \text{ C}$$

$$T_o = 25 \text{ C}$$

- Potential Speed Increase*:

⇒ 25%

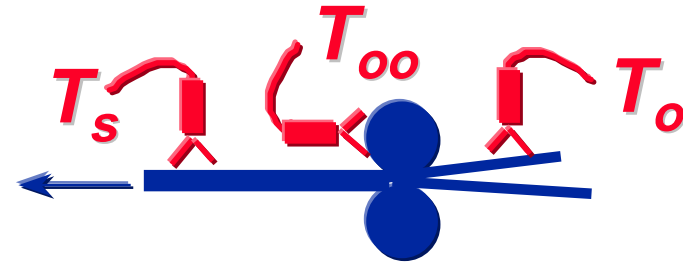

$$\overline{\Delta T} = \frac{T_{\infty} - T_s}{T_s - T_o}$$

*Assuming all other factors are permitting



Example Speed Boost: Laminating

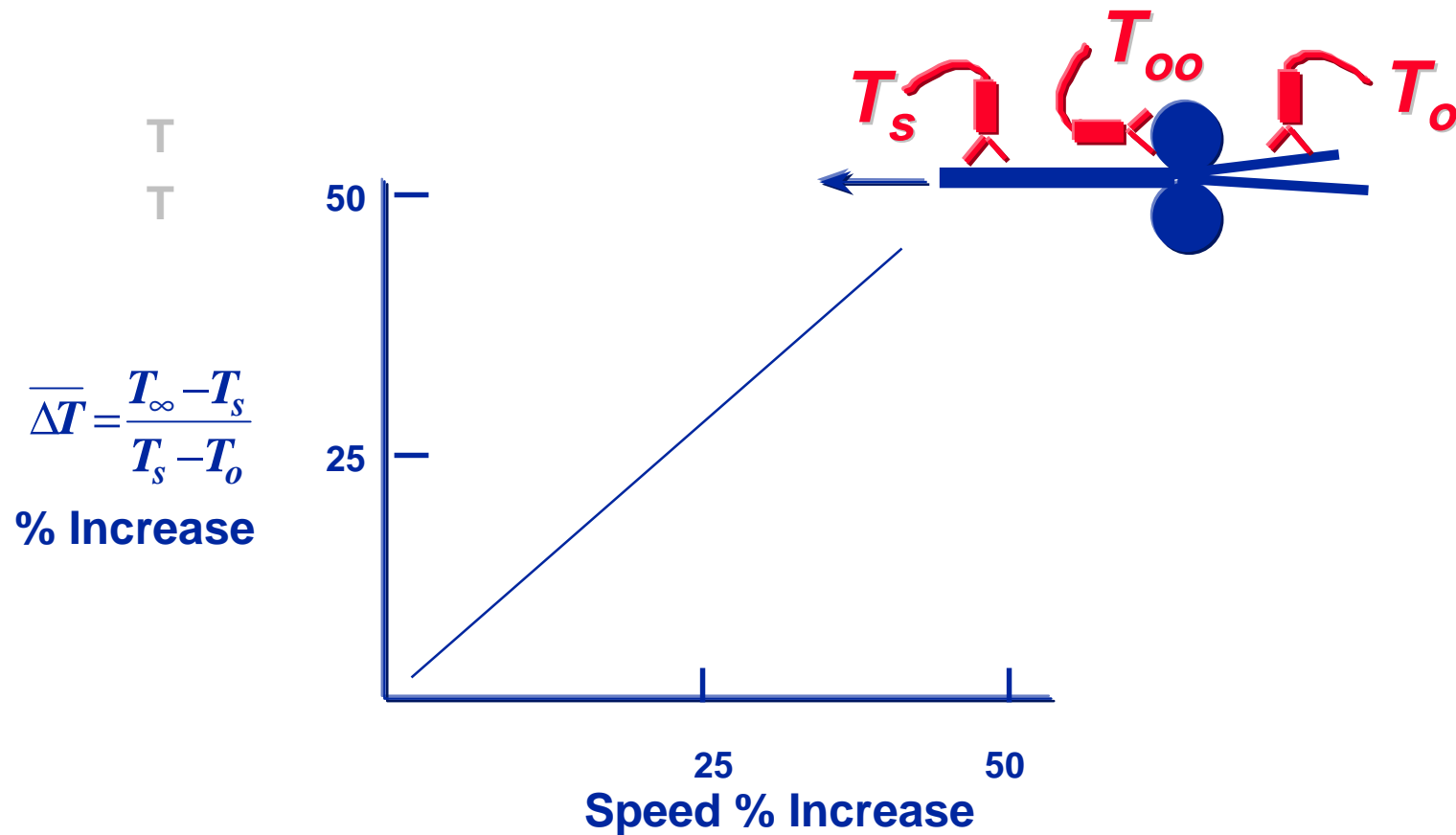

Increasing Production Speeds via IR -Controlled Heat Balance

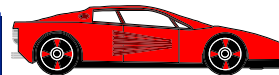

EXERGEN
CORPORATION

Example Speed Boost: Laminating

- Existing Set-up:

$$T_{\infty} = 105 \text{ C}$$

$$T_s = 85 \text{ C}$$

$$T_o = 25 \text{ C}$$

- New Set-up:

$$T_{\infty} = 120 \text{ C}$$

$$T_s = 85 \text{ C}$$

$$T_o = 25 \text{ C}$$

- Potential Speed Increase*:

⇒ 50%

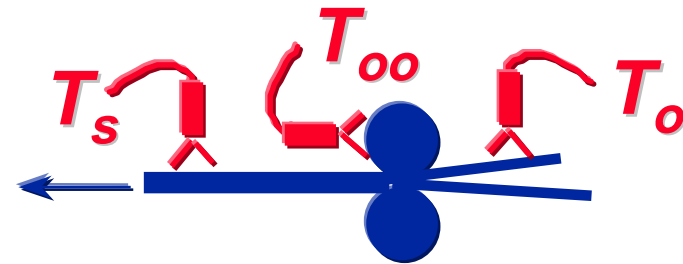

$$\overline{\Delta T} = \frac{T_{\infty} - T_s}{T_s - T_o}$$

*Assuming all other factors are permitting

Increasing Production Speeds via IR -Controlled Heat Balance

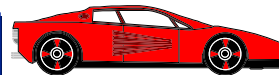

EXERGEN
CORPORATION

Example Speed Boost: Drying

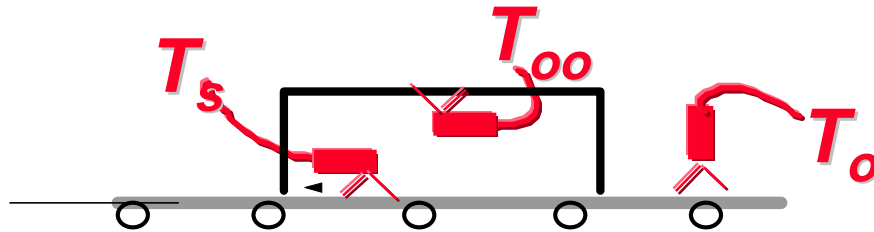

- **To Achieve 20% Production Speed Increase**

ratio $\Delta T = \frac{T_{\infty} - T_s}{T_s - T_o}$ must increase by 20%

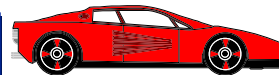

Example Speed Boost: Drying

- Existing Set-up:

$$T_{\infty} = 260 \text{ C}$$

$$T_s = 85 \text{ C}$$

$$T_o = 25 \text{ C}$$

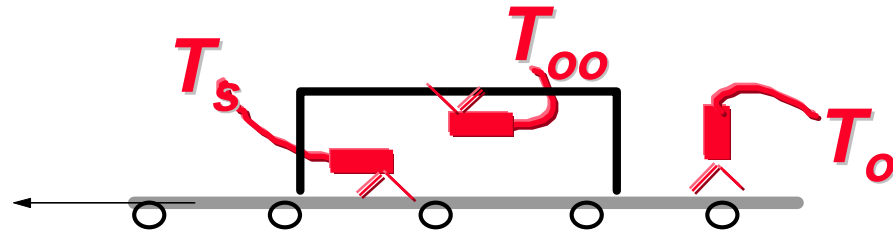

- New Set-up:

$$T_{\infty} = 260 \text{ C}$$

$$T_s = 85 \text{ C}$$

$$T_o = 40 \text{ C (with preheat)}$$

$$\overline{\Delta T} = \frac{T_{\infty} - T_s}{T_s - T_o}$$

- Potential Speed Increase*:

⇒ 38%

*Assuming all other factors are permitting

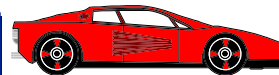

Precision Drying Control for Maximum Production Speed

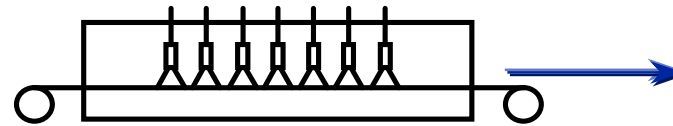
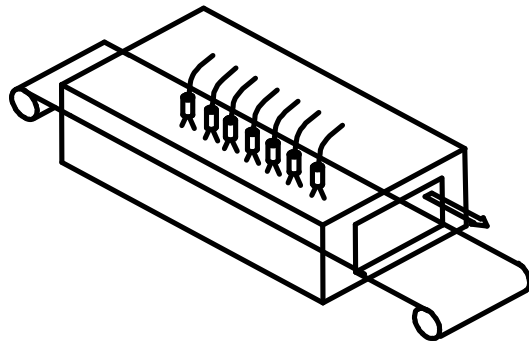

**Relative Temperatures
at IRt/c Locations**

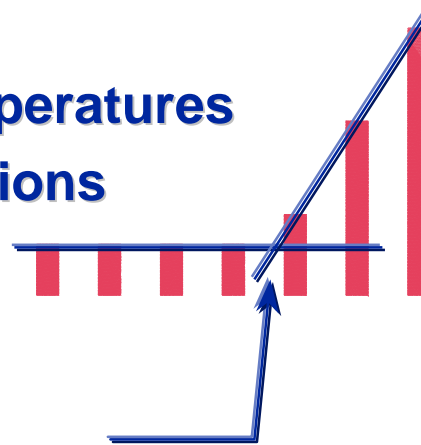

Dry-Out Point (Phase Change)

Increasing Production Speeds via IR -Controlled Heat Balance

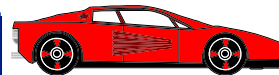

EXERGEN
CORPORATION

Example Speed Boost: Heat Sealing

- Existing Set-up:

$$T_{\infty} = 150 \text{ C}$$

$$T_s = 120 \text{ C}$$

$$T_o = 25 \text{ C}$$

- New Set-up:

$$T_{\infty} = 150 \text{ C}$$

$$T_s = 120 \text{ C}$$

$$T_o = 45 \text{ C (with preheat added)}$$

- Potential Speed Increase:

⇒ 20%

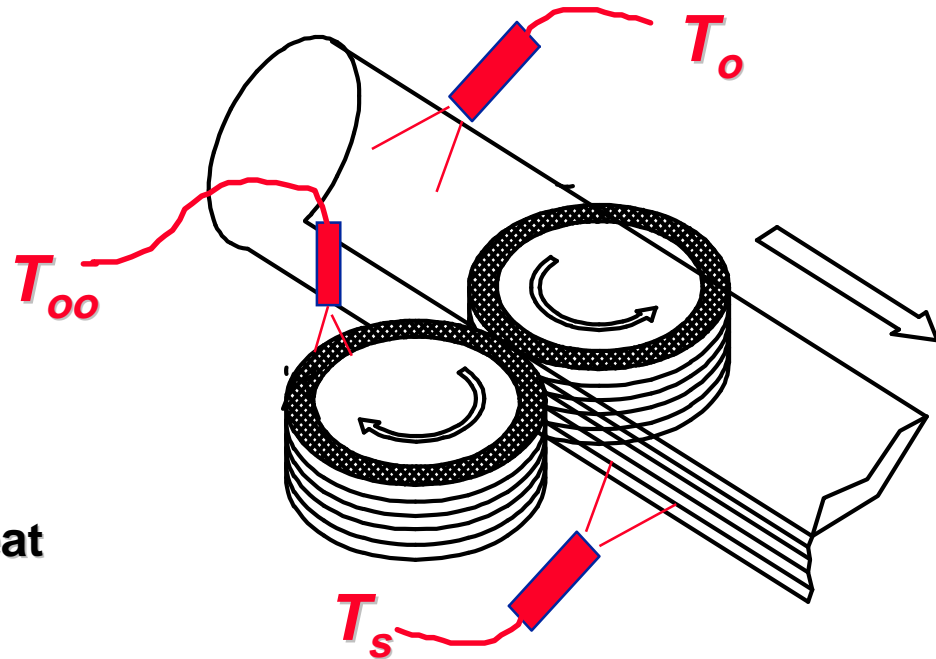

$$\overline{\Delta T} = \frac{T_{\infty} - T_s}{T_s - T_o}$$

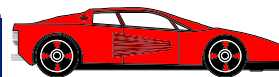

The Exergen Creed

*We are the best in the world at
what we do,*

*And our products and services must
be commensurate with our mission
of supplying our customers with the
best,*

*To help them be the best in the
world at what they do.*

*F. Pompei
President and Founder*

© Exergen Corporation 1996

Increasing Production Speeds via IR -Controlled Heat Balance

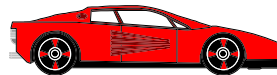

EXERGEN
CORPORATION