

Transmitter

IRt/c.XMTR

In-Line Pre-Calibrated 4-20 mA Transmitter



The t/c.XMTR is specifically designed to interface any model IRt/c by a simple thermocouple connector or splice. The two wire current loop can be used in any conventional 4-20mA, 0-5V or 0-10V circuit that is scaled for the temperature range of interest.

For OEMs, IRt/c sensors and t/c.XMTR can be supplied pre-wired together.

- Use any existing wiring, for easy low cost installation
- Use existing PLC, computer or controller inputs
- In line design requires no mechanical support
- Pre-calibrated for IRt/c type, no span or zero adjustment necessary
- Hermetically sealed construction exceeds NEMA 4, 4X, IP65, 66, 67
- Stainless Steel construction can withstand harsh environments

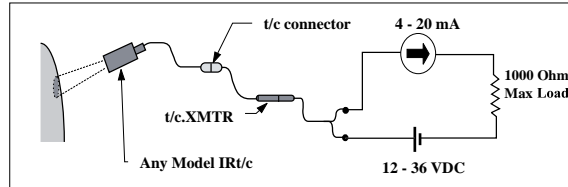
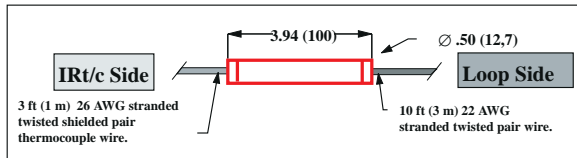

	J150 K150	J500 K500	J1200 K1200	K2100	S3000
Temperature at 4 mA	32°F (0°C)				
Temperature at 20 mA	150°F (65°C)	500°F (260°C)	1000°F (540°C)	2000°F (1100°C)	3000°F (1650°C)
Accuracy	±0.1% F.S. conversion of thermocouple mV input to mA output				
Speed of Response	160 msec (10Hz bandwidth)				
Operating Range	32 to 158°F (0 to 70°C)				
Temperature Drift	<0.02% F.S. per °C				
Output Noise	<1nv rms (100Hz bandwidth)				
Input Break Indication	Upscale: goes to >20 mA				
Power Supply @ Load Storage Temperature	12 VDC minimum @10; to 22 VDC minimum @1K -85 to 257°F (-65 to 125°C)				
Weight	2.4 oz (68 g) with cables				
Housing	Stainless steel, hermetically sealed, meets or exceeds all applicable NEMA ratings, housing electrically isolated from signal.				



IRt/c for Ambient >100°C Cooling Requirements

Up to 450°F (230°C), air alone can provide sufficient cooling with the Cooling Jacket Kit. As the Air Cooling Chart illustrates, considerably less air is required to cool an IRt/c with a CJK-1 or CJK-2, than an IRt/c.5. For this reason, the IRt/c is recommended for hot areas if it is possible to bring the sensor close to the target.

The air cooling chart extends above the recommended 450°F (230°C), and can be used there, but caution is advised due to the possible effects of hot spots.

If air consumption is of concern, or if ambient temperatures are above 450°F (230°C), water cooling is recommended. A small amount of purge air is also recommended when water cooling (see Tech Note #15).

Air Cooling Chart

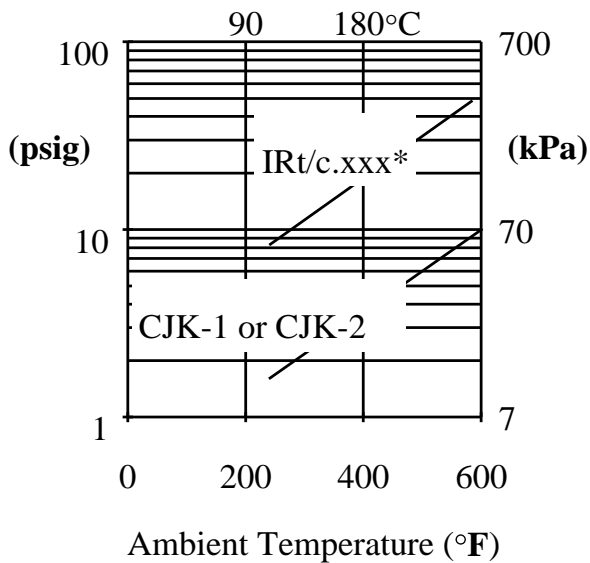

Air Flow Requirements

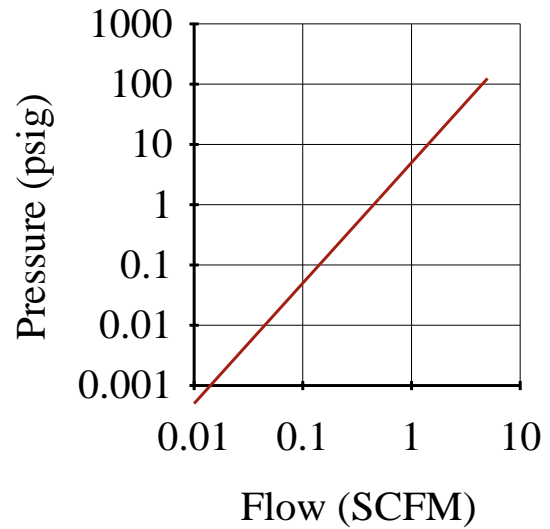

Chart applies to standard ovens. For forced convection ovens, multiply air pressure by 3, or add external sleeve with insulating stagnant air gap.

Air pressure required to cool IRt/c with CJK-1 or CJK-2 at various ambient temperatures, compared to requirement for IRt/c models with built-in air cooling.

To estimate air flow requirements, select the pressure required from the Air Cooling Chart, and read air flow above.

***All other IRt/c's with built-in air cooling.**

CJK-1

for IRt/c, IRt/c.3X, IRt/c.1X
Water/Air Cooling

A convenient and inexpensive kit makes it possible to use the IRt/c with air, water, or both for service in harsh environments. Measuring only 1" x 4.16" (25 x 106 mm) overall, the CJK-1 is physically small enough to fit into tight areas and closely monitor process temperatures from the optimum position - up close. With its all stainless steel housing, it can withstand the harshest environments.

Extraordinarily efficient in design, the CJK requires only .05 gpm (190 cc/min) of water and 0.1 CFM (3000 cc/min) of air to protect an IRt/c at 1000°F (540°C).

Features

- Small size - 1" dia. x 4.16" lg. (25 x 106mm)
- Stainless steel housing
- Seamless copper monotube cooling coil
- Complete equipment for air cooling and/or water cooling
- Air purge included
- Super-efficient design for low air and water use
- Fits IRt/c, IRt/c.1X, IRt/c.3X
- Water cooling to 1000°F (540°C) with as little as 0.05 gpm (190 cc/min) and 0.1 CFM (3000 cc/min) of air

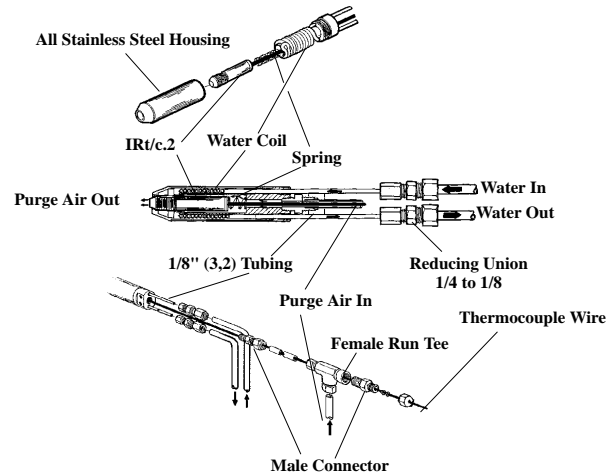

Water Cooling Configuration.
All fittings required are supplied.
Water flow > .05 gpm (190 cc/min).

The water cooling system consists of a seamless monotube, in order to eliminate the possibility of leaking joints. For convenience, the seamless tubing extends 3 ft (1 m) from the rear of the housing.

CJK-1 Housing Dimensions

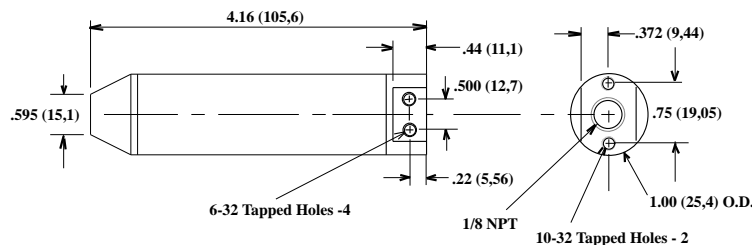

Cooling Jacket Kits

CJK-2

For IRt/c.3X only
Air Only Cooling



Features

- Cooling up to 750°F (450°C)
- Small size - 1" dia. x 3" lg. (76 x 25.4mm)
- Stainless steel housing
- Available with brass or stainless fittings
- Air purge included
- Ultra-efficient design for low air consumption and maximum cooling efficiency
- Side venting for variable air flow

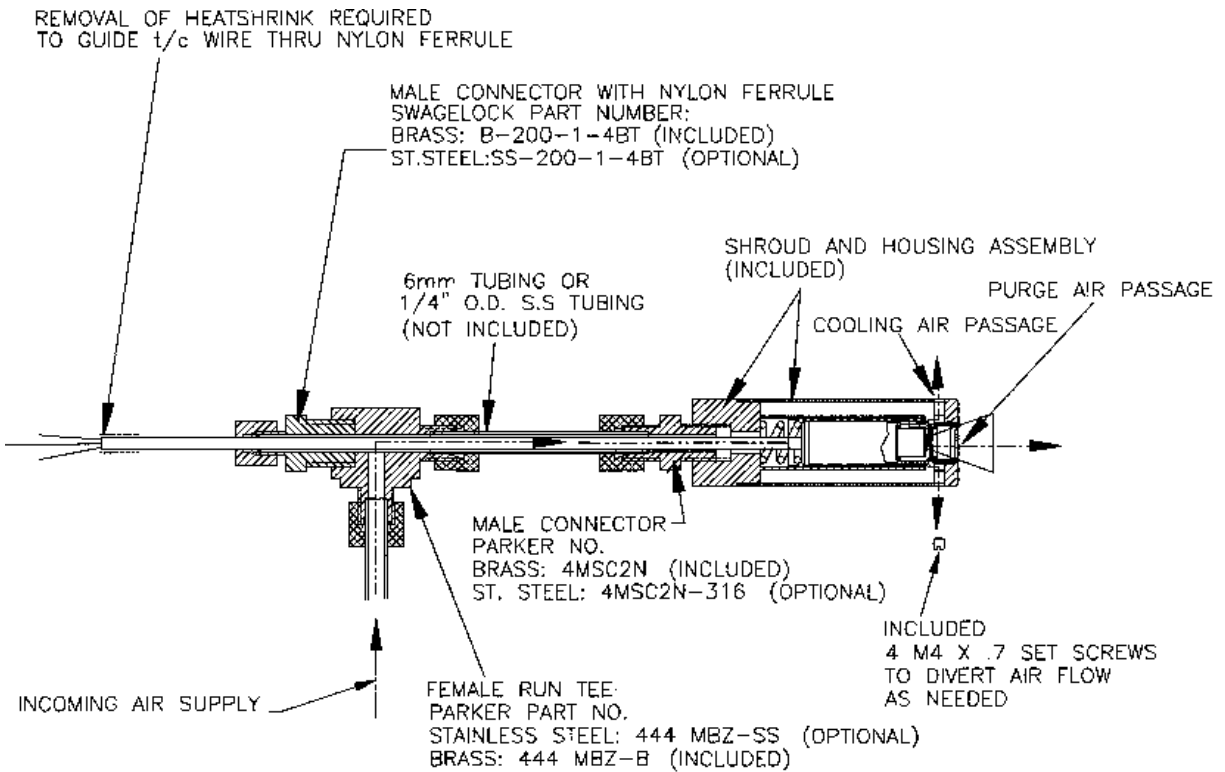

MB-1

Multi-Purpose Mounting Bracket

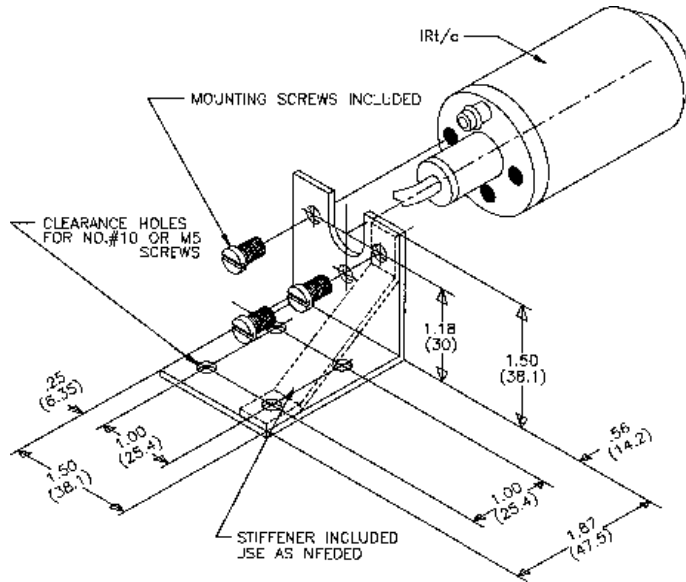
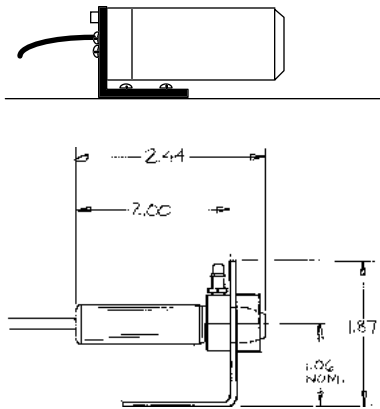

APK-1, APK-2

Pumps for Purge Air APK-1 120VAC APK-2 12VDC

The convenient Air Pump Kit allows for fast and easy installation of an air source suitable for maintaining optical cleanliness of IRt/c's in dirty, dusty environments. Its air flow is sufficient to keep up to five IRt/c.2, or one IRt/c.5 clean. Additionally, the air flow is sufficient to allow an IRt/c.2 to operate in ambients up to 240°F (115°C). The pump can be mounted on either horizontal or vertical surfaces.

Specifications:

- Air Pump - 120VAC, 120 cu.in./min (1960cc/min). Available in 12VDC.
- Vinyl Tubing - 10 ft (3m), .25" (6mm) OD, .17" (4mm) ID.
- Standoff Mounts - allow pump to be secured vertically or horizontally.

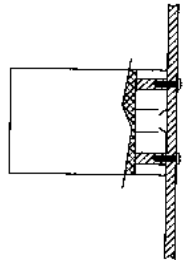
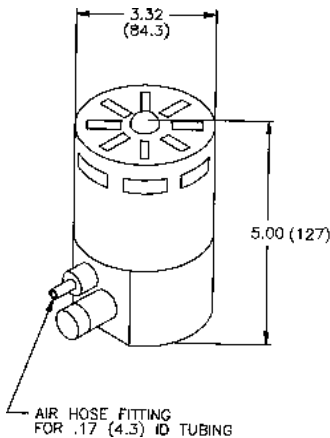

VERTICAL MOUNTING

Connector Kit

Thermocouple Connectors with Shield

- Easy Installation of IRt/c, with up to 1000' (300 m) Extension Cable
- Connector Ground Protects Against Electrical Noise Errors
- Write-On Area for Easy Identification
- Superior Mechanical Connection Prevents Signal Loss due to Vibration or Wire Movement
- Rugged Glass-Filled Nylon Shell Rated to 425°F (218°C)
- High Purity Thermocouple Alloy Pins and Sockets
- Available in J, K, E, T Types

to assure high accuracy. Each connector includes a write-on insert and an external ground strap to maintain the electrical connection of the ground wire and strengthen the mechanical connection between connectors.

The new IRt/c miniature low noise connectors are designed to provide an easy connection of ground wires to IRt/c's and extension wire. The drain wire of a 20 AWG twisted shield cable or the shield of the overbraided wire is crimped and held in place by the internal hardware. They have excellent thermal and electrical characteristics

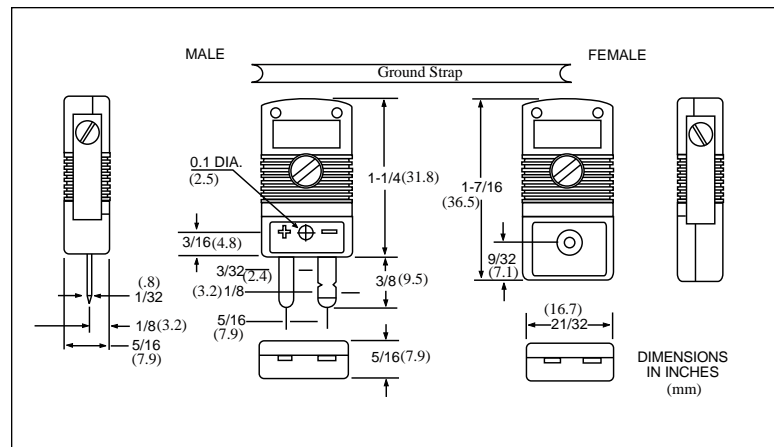

T/C Cable

Twisted Shielded Pair Extension Cable

- Twisted Shielded Pair for High Noise Rejection
- Can Be Used Up To 1000' (300 m) Length
- FEP Teflon Jacket/Insulators - Service Temperature to 392°F (200°C)
- Highest Accuracy - Thermocouple Grade Wire
- Available In J, K, E, T Types

Although commonly available thermocouple extension wire may be used with IRt/c's, twisted shielded pair wire is preferred due to its much superior noise rejection characteristics. This feature is particularly important when using IRt/c's with long extensions in electrically noisy environments, due to the relatively high impedance of IRt/c's compared to ordinary thermocouples.

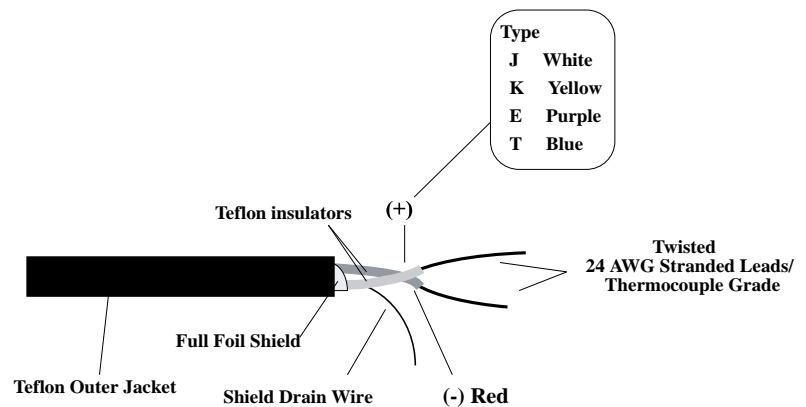

Gooseneck Mounting Kit

GMK-1

For fast, convenient testing of IRt/c's

For fast and convenient mounting of IRt/c's, especially for testing, the Gooseneck Mounting Kit provides an inexpensive method to quickly install an IRt/c directly on the production line. Its heavy duty design provides excellent stiffness for reliable positioning. Clamps are fabricated of aluminum for durable performance. The sensor clamp fits all IRt/c models (the MB-1 Mounting Bracket is required for Adjustable IRt/c models),

