

<i>Tech Note #</i>	
#1 Quick Installation Guide	#30 Vibrating Objects
#2 Auto-Tune Controllers	#31 What is Emissivity?
#3 Extension Wire Length	#32 Where is the Emissivity Adjustment?
#4 Paint Curing	#33 Calibrating with the D-Series
#5 Medical Diagnostic Equipment	#34 Ambient Temperature
#6 Furnace Electrical Isolation	#35 Air Purge/Cooling Requirements
#7 Steaming Environments	#36 Reflective Cup for Silicon Wafer
#8 Spinning Rotor in Vacuum	#37 Selecting Temperature Controllers
#9 Plastic Injection Mold	#38 Reliability
#10 Intrinsically Safe	#39 Self-test for IRT/c
#11 Reduces Air Purge	#40 Monitoring Plastic Extrusion
#12 Monitor Mechanical Drive	#41 IRT/c.5
#13 Monitors Tire Temperatures	#42 Hazardous Materials
#14 Multiplexed Datalogging	#43 Dough Mixing
#15 Air Purging/Water Cooling	#44 Induction Heating
#16 Offsets Leakage Currents	#45 Printing/Ink Drying
#17 Disposable Infrared Sensor	#46 Discrete Parts Monitoring
#18 Hot Melt Adhesives	#47 Electric Power Distribution
#19 Pit Viper	#48 Glass Monitoring
#20 Relative Humidity Measurement	#49 Temperature Selection Guide
#21 Controlling Web Roller Temperature	#50 Improving Maching Tolerance
#22 Vacuum & Thermoforming	#51 Asphalt Temperature Monitoring
#23 Printed Circuit Board	#52 Speed of Response
#24 Drying Paper, Wood, Textiles, Film	#53 Quick Selection Guide
#25 Cooling Jacket Kit	#54 How to Use Infrared Effectively
#26 Long Term Accuracy	#55 Understanding Field-of-View
#27 Air Pump Accessory	#56 Calibrating with Simulators
#28 Trouble Shooting Guide	#57 Measuring Small Objects
#29 Oblique Measuring	#58 Measuring High Temperatures

<i>Tech Note #</i>	
#59 Lo E Filter Reduces Errors	#80 Unique "Slot Spot"
#60 Adjustable Models/Set-up & Calibration	#81 Monitoring Web Processes
#61 Adjustable Models	#82 Grounding & Shielding
#62 Color Does Not Affect Readings	#83 Monitoring in Dirty/Vapor Filled Environments
#63 Ambient Temperature Effects	#84 Usage in High Electrical Noise Area
#64 Reflective Errors	#85 Selection/Application for OEM's
#65 Painting Metal Surfaces/Emissivity	#86 Infrared Scanning Arrays with IRt/c.01
#66 Sight Windows & Lo E Filter Models	#87 Two-Color Pyrometry
#67 Dry-out Point in Web Production	#88 Measuring Tire Tread Internal Temperature
#68 Fail-Safe Control Installation Models	#89 Real World Performance Accuracy
#69 Selecting Hi E or Lo E Emissivity Table	#90 More Accurate than Conventional IR
#70 Calibrating Wide Linear Range	#91 Disposable Window
#71 Printing Press Applications	#92 Drying Paper Webs with IRt/c's
#72 OEM Low Cost Interface	#93 Pre-Calibrated Transmitter for Easy Installation
#73 Flame Detection	#94 Easy Upgrade with IRt/c & t/c.XMTR
#74 Calibrating Testing Procedures	#95 Precalibrated Hi E & Lo E Models for OEM Applications
#75 Calibration with Boiling Water	#96 Non-Contact Heat Sealing Temperature Control/Packaging Machinery
#76 Aperture Kit Usage	#97 Web Drying for Transparent & Reflective Films, Paper & Textiles
#77 IRt/c Tested at 5000psig Pressure	#98 Heated Metal Rollers / Web Processes To Increase Production
#78 IRt/c Tested for Vacuum & Microwave Compatibility	#99 IRt/c Heat Balance Series for Medical Applications
#79 IRt/c's Withstand 1000G Shock	

	<i>Tech Note</i>
Adhesives	18
Air Purge Cooling Requirements	34
Asphalt	51
Automotive	13, 88
Cure Monitoring/Control	4, 86, 97
Destructive Testing	17
Dirty or Vapor-Filled Environments	83
Disposable Windows	92
Drying	24, 45, 67, 93, 97
Electrical Noise Areas	84
Electrical Power	47
Electronics	23
Extrusions	40
Film	24, 97
Food	43
Glass	48
Humidity	20
In-Process Testing	8, 12, 13, 21, 42, 46, 73, 88
Induction Heating	44
Injection Molding	9
Ink	45
Machining	50
Medical	5, 99
Metal Surfaces	65

Exergen's library of IRt/c Tech Notes is always growing. If you do not see the topic which interests you, please call. To be notified of updates to the IRt/c Catalog and Book of Tech Notes, please fax or mail the reply card in the back of this book. If the card is missing, contact Exergen.

	<i>Tech Note</i>
Multiplexed Datalogging	14
Packaging	81, 86, 97, 98
Paint	4, 86
Paper	24, 93, 97
Parts Monitoring	46
Plastics	9, 40
Printed Circuit Boards	23
Printing	45, 67, 71, 81, 86
Radiant Heaters	4, 22
Rollers	21, 98
Scanning Arrays	86
Sight Windows	66
Small Objects	57
Software Self-Testing	39
Steam Heating	7
Textiles	24, 97
Thermocouple Simulators, Calibration with	56
Thermoforming	22
Thermowells	58
Transmitters	94, 95
Two-Color Pyrometry	87
Vacuum Forming	22
Vacuum Furnace	6
Vibrating Objects	30
Web Processes	21, 67, 81, 86, 93, 98
Wood	24

Quick Installation Guide Pre-Calibrated Models

All infrared-based sensing systems must be calibrated for specific material surface properties (for example, the amount of heat radiated from the target surface, environmental heat reflections, etc.). This calibration is performed by measuring the target surface temperature with a reliable independent surface temperature probe. The easiest and fastest method of accurately calibrating out these effects is to use an Exergen Microscanner D-Series hand-held Infrared Thermometer with a patented Automatic Emissivity Compensation System, which gives a true reading regardless of emissivity. Your Authorized IRt/c Distributor will be pleased to make a D-Series available for your installation. To calibrate Adjustable models (IRt/c.xxA) see Tech Note No. 60.

The following procedure is recommended:

1. Install the IRt/c as close as practical to view the target material to be measured.
2. Wire the IRt/c to the controller, PLC, transmitter, etc. in standard fashion (including ground shield as in Tech Note #82). As with conventional thermocouples, red wire is always (-).

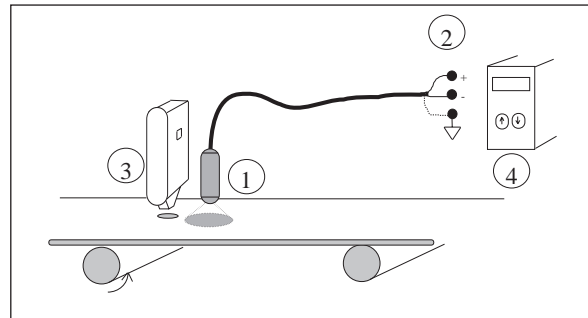

3. Bring the process up to normal operating temperature and measure the actual temperature of the target material with the Microscanner D-Series Infrared Thermometer.
4. Adjust "input offset," "zero," "low cal," on the readout device to match the Microscanner reading.

Installation Complete. (For OEM installations preset the same adjustments. Individual calibration is not required.)

IRt/c Setup With Auto-Tune Temperature Controllers

In many applications, heating elements are employed to heat a product in an oven, furnace, or with jets of hot air. Conventional control devices using contact thermocouples measure and control the oven air temperature, IR heating element temperature, or air jet temperature in an effort to maintain product temperature and therefore, quality; often with less than satisfactory results.

Replacing the contact thermocouple (for example, measuring oven temperature) with a non-contact IRt/c measuring product temperature directly will insure that product temperature is maintained.

Some readjustment of the controller parameters is required because of differences in sensor response times (an IRt/c is much faster) and time required to heat the product compared to the original sensor (slower). After installing the IRt/c and calibrating the controller reading using a Microscanner D-Series (see Tech Note #1), initiate the self-tuning cycle of

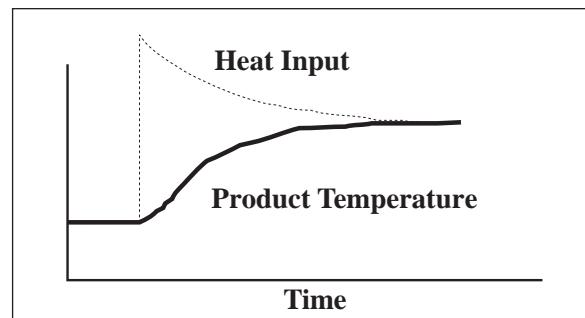

the controller and check to see that the control is stable and accurate. If it will not self tune properly, manually adjust the control coefficients to achieve stable control. Because the product temperature is likely to change temperature more slowly than the original sensor, start with slowly increasing the "D" of the PID coefficients.

IRt/c can be used with up to 1,000 feet (300 m) of Thermocouple Extension Wire

Tech Note
3

With twisted shielded pair thermocouple extension wire, an IRt/c can be mounted as far as 1,000 ft (300 meters) from the readout device, even in a very fierce electrical noise environment. The extraordinary noise suppression characteristics designed into the IRt/c make this possible, without using a transmitter. The IRt/c housing is electrically isolated from the signal leads and is connected to the shielded ground of the extension cable. For long distances, the twisted shielded extension cable should be used, and the shield connected to a good electrical ground.

A demonstration test was performed with a 1000 ft (300 m) coil of twisted shielded pair of extension wire, with 100 ft (30 m) unwound, connecting an IRt/c to a fast (100 msec response) A/D conversion module to a computer. As a noise generator, a 60

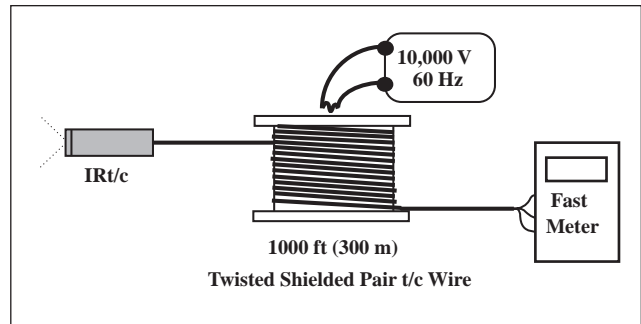

Hz 10,000 volt transformer and spark generator was set up to spark within 6 inches (15 cm) of the wire. The test results showed less than 0.1°C of noise at any relative position of the wire, spark, and transformer.

IRt/c Controls Paint Curing With Radiant Heaters

Tech Note
4

A rather logical combination of heating method and control is radiant heat with an IRt/c for control. They work extraordinarily well together, since both the heating and measuring occur right at the surface, where the paint is located. The IRt/c reading is unaffected by reflections from the heater, since the spectral response of the 6-14 micron IRt/c lens filters out the shorter wavelengths of the radiant heater energy.

The IRt/c may be mounted in the shroud or reflector of the radiant heater, such that it can see through the elements. Select any of the IRt/c models, depending on the field-of-view required to see past the elements to the painted surface. Test the location by turning on the heater with no target present. The change in reading should be small. Care should be taken in mounting the IRt/c in such a way as to keep its temperature below 200°F (93°C) and to keep the lens clean. The IRt/c.3x, .5, and .10 are the preferred models for this application because of their built-in air purge. They can be used in

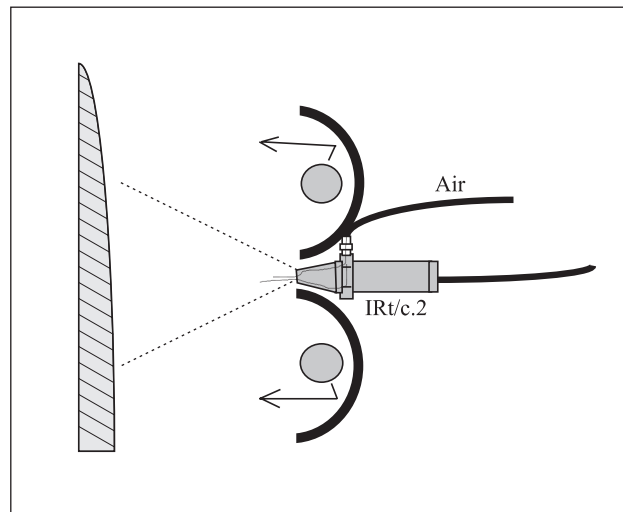

environments with temperatures up to 250°F (121°C) or higher when the air purge system is used. The narrow fields-of-view allow more leeway in positioning, and thus more flexibility in installation.

IRt/c for Medical Diagnostic Equipment: IRt/c.2G-J-37

Many processes in clinical diagnostics and therapies involve blood samples and other fluids that must be heated to 98.6°F (37°C) for optimum performance. Since sterility and absolute prevention of contamination are paramount, measuring and controlling fluid temperatures is not a trivial task. Using accurate thermistors or thermocouples in the disposable fluid handling components is generally much too expensive, and use of contact devices creates the risk contamination and inaccuracies.

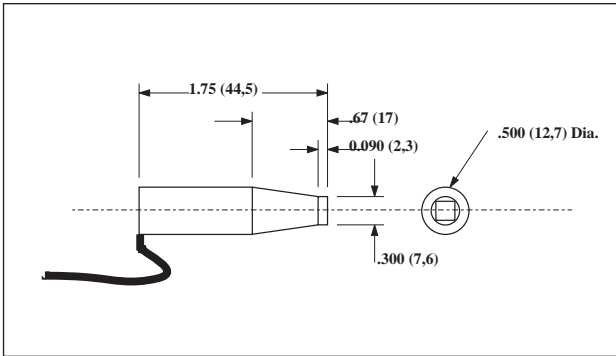
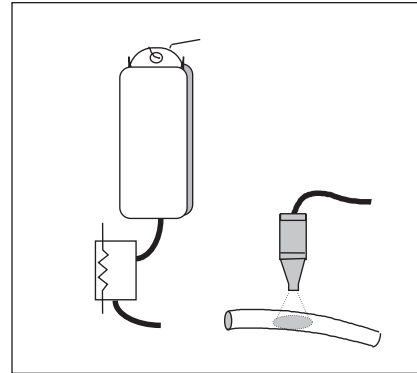

The IRt/c is an excellent solution to the problem. Its small size, low cost, and easy interface with standard thermocouple closed-loop control circuitry are ideal. The IRt/c.2G J-37 is designed and calibrated to be highly accurate at 37°C. The J-type is offered because the leads are easily soldered to circuit boards with standard materials, and off-the-shelf cold junction compensation amplifiers are available. It is equipped with a hard pure germanium crystal lens that withstands repeated cleanings, and a fail-safe xenon gas fill system. Its hermetically sealed stainless steel construction permits it to be gas sterilized.

IRt/c Solves Vacuum Furnace Electrical Isolation Problem

A vacuum furnace manufacturer employs a heat treating process in which the metal parts experience an electrical potential of 1000 volts. To control the heating process to produce the correct metallurgical properties, a conventional thermocouple embedded in one of the parts produces the temperature signal for the controller. However, since the parts are at 1000 volts, an elaborate electrical isolation system has to be employed to permit the thermocouple to work safely, at a cost of well over \$2,000.

Replacing the contact thermocouple with a non-contact IRt/c, the manufacturer effectively replaced \$2,000 worth of equipment with about 1 inch (2.5 cm) of vacuum separation between the IRt/c and test part - which is free. Unlike a contact thermocouple, the IRt/c can easily see the part through the vacuum, measure its temperature without touching,

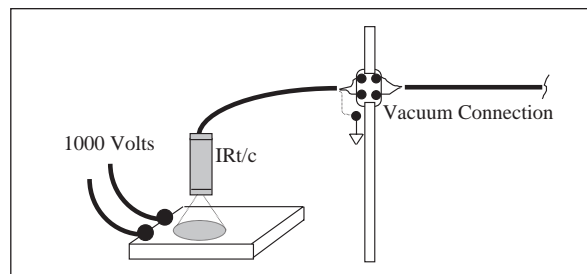

remaining completely isolated electrically by the gap between the part and IRt/c. Since the part is heated to 1000°F (538°C), an aluminum clamp is employed as a heat sink to keep the IRt/c itself below 200°F (93°C). Since the part emissivity is low (shiny metal) the test part has a small area painted with Rustoleum® Barbecue Black Paint, rated to 1300°F (704°C), to raise the emissivity.

Temperature Measurements in Steaming Environments

Tech Note

7

A common problem in processing of paper and other material is measuring temperature in an area in which steam (water) is used to heat and cool the material. The resulting steam vapor makes it very difficult to use non-contact infrared devices because steam vapor is opaque to infrared wavelengths commonly used, i.e. the sensor cannot see through the vapor fog very well, and thus would report temperatures that were too low. In addition, condensing steam vapor on the sensor lens would render the IRt/c completely blind to infrared wavelengths.

The IRt/c air purge models solve the problems in a simple and inexpensive fashion. The air jet from the built-in air purge clears a path to the target material by "blowing away" the steam vapor in the optical

path, replacing it with dry air. Care is required in the set-up of distance to the target and air pressure employed, to prevent cooling of the target area by the air jet.

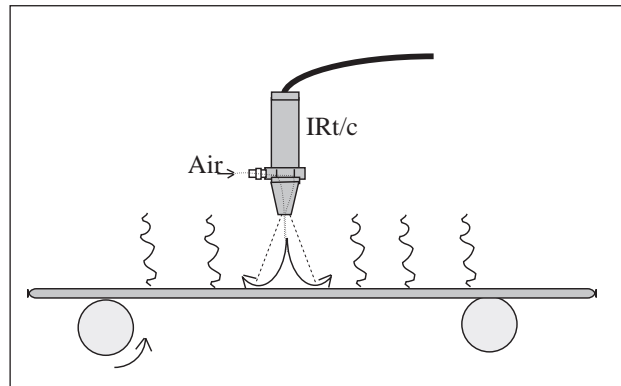

Rotor Disk Tests in Vacuum

Tech Note

8

Large steam and gas turbine rotor disks require spin testing to assure mechanical reliability at the high forces experienced during full speed operation. This testing is usually conducted in a large vacuum chamber to minimize the required power to drive the rotor. However, the vacuum is not perfect and rotor heating does occur during the test. To properly assess performance, the disk temperature must be known. Standard methods of measuring temperature, such as disk-mounted sensors, using slip rings or telemetry to transmit the data, are clumsy and expensive.

The IRt/c can directly measure the temperature of the rotor under full speed conditions. With its hermetically sealed construction, the IRt/c operates in a vacuum without any requirement for protection. Its thermocouple leads can be connected to a standard thermocouple vacuum connector.

Test installation design considerations should include IRt/c body temperature and target emissivity. To assure that the IRt/c will remain below 200°F (95°C) even with very hot targets, use a solid metal mounting arrangement to heat sink the IRt/c body,

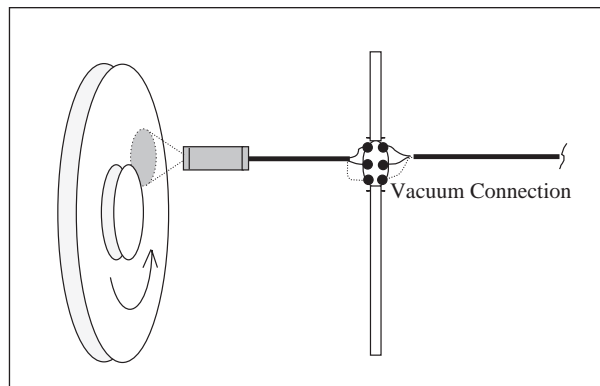

since the internal construction is designed to readily conduct away the radiated heat. For emissivity considerations, a shiny metal rotor disk should have black painted stripes in the areas of measurement. For best accuracy, the IRt/c read-out device can be calibrated to the precise surface conditions by using a Microscanner D-Series.

IRt/c Monitors Plastic Injection Mold Clearing

In high volume plastic injection molding machinery, a molded part that does not clear the mold can cause serious problems, including a long down time to clean up or make repairs.

A particularly useful property of the mold is its shininess, which means low emissivity. Accordingly, the infrared radiation from an open mold is primarily reflected from the room, and thus an IRt/c pointed at the mold would not read much higher than room temperature. However, if a part is still in the mold, the IR radiation is far higher since the high emissivity of the plastic part is easily seen by the IRt/c as the temperature of the hot part. By mounting an IRt/c so that it can view the part as the mold opens, a reliable and inexpensive part detection system can be installed. Simply connect the IRt/c to a simple thermocouple controller with alarms interfaced to the mold position. For efficient coverage of the mold, two IRt/c's can be wired in parallel and connected to a single controller, so that a part viewed by either sensor will alarm.

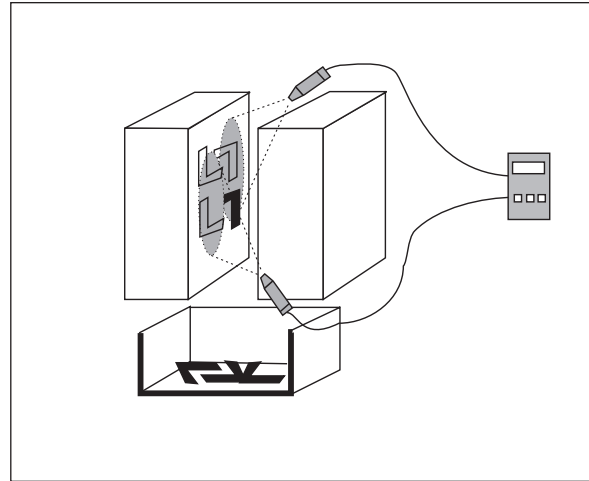

For harsh environments, the IRt/c.3x or IRt/c.5 models with narrow field-of-view and built-in air purge are recommended.

IRt/c's are Intrinsically Safe When Used with Barriers

"Field Apparatus having energy storing or generating characteristics of <math><1.2V, 0.1A, 25\text{ mW}</math> or 25 microJ shall be considered Simple Apparatus (non-energy storing). These general purpose devices may be used in a hazardous (classified) location without further approval when connected to a certified intrinsically safe circuit." -**Quote from R. Stahl, Inc. Comprehensive Product Manual On Intrinsic Safety Barrier and Repeater Relays.** Examples of non-energy storing Intrinsically Safe Apparatus are:

- Thermocouples, RTD's, LED's
- Dry Switch Contacts
- NAMUR Inductive Proximity Switches
- Non-inductive Strain Gauge Devices and Resistors

The IRt/c falls into the category of thermocouples, since it generates its signal by converting the radiated heat energy to an electrical signal via Seebeck effects, the basic driving force of thermocouples. Like all thermocouples, it requires no power source and generates signals measured in millivolts of voltage, microamps of current and nanowatts of power. IRt/c's have a small capacitance, but at one microFarad, the energy storage is measured in nanojoules and is a thousand times lower than the 25 microjoule criterion.

Accordingly, the IRt/c qualifies as a Simple Apparatus for use in hazardous locations, and with the appropriate barrier, qualifies as Intrinsically Safe.

IRt/c.3x Reduces Air Purge Air Consumption by a Factor of 100

Tech Note
11

An air purge is ideal for keeping the lenses of infrared temperature sensing heads in continuous manufacturing duty service clean, especially in particularly dirty or oily environments. Even a small amount of dirt or oil coating on a lens can affect the reading: if 5% of the lens area is covered, then 5% of the reading is lost. For conventional IR devices, with lens size of 1" (2.5 cm) or more, upwards of 1 CFM (.03 cubic meter/min.) is required to maintain cleanliness. At typical costs for plant compressed air, a single continuous duty conventional IR sensor uses approximately **\$100 of air per year**. Clearly, if a plant has many IR installations, the cost of air is of considerable concern.

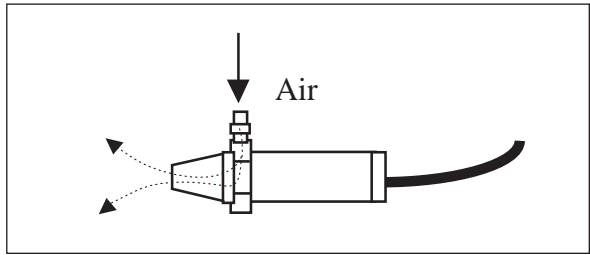
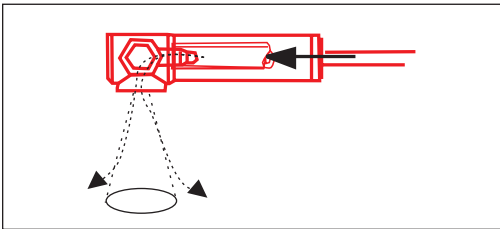

The small 1/4 inch (.6 cm) lenses of the IRt/c.3x and IRt/c.3SV make it possible to purge with as little as .01 CFM (.0003 cubic meters/min.) of air. With such a small amount of air, it becomes possible to use instrument air, if it is conveniently available, which is already clean and dry, without adding the additional hardware to clean and dry the IR purge air. In addition, the IRt/c.3x can be air purged with a small inexpensive air pump (model APK-1), thus not requiring a plant air source. At the very low flow rate, the IRt/c air cost is only approximately \$1 per year, a 100-fold reduction over conventional IR devices.

IRt/c Monitors Mechanical Drives for Bearing Failure

Tech Note
12

For certain highly loaded mechanical drive elements, such as the main rotor drive for a helicopter, it is imperative that impending failure be detected before a catastrophe occurs. A central element of the drive, such as a universal joint or coupling, will telegraph its impending failure well in advance by displaying an increase in temperature. For example, if a drive transmitting 1000 hp (750 kW) of shaft power with a universal joint loses only 0.1% in drive efficiency, the joint will increase in temperature as much as several hundred degrees until it is able to dissipate an additional 750 watts of energy as heat. This increase in temperature is a direct and reliable indication of the increased inefficiency caused by a degradation in parts performance.

Monitoring the joint with an IRt/c provides a fast and direct indication of joint temperature, and thus the increasing inefficiency due to wear or failure. A more sensitive method of monitoring the joint is to employ two IRt/c's wired differentially (connecting the two minus leads together and measuring across the plus leads, see example), measuring the difference in

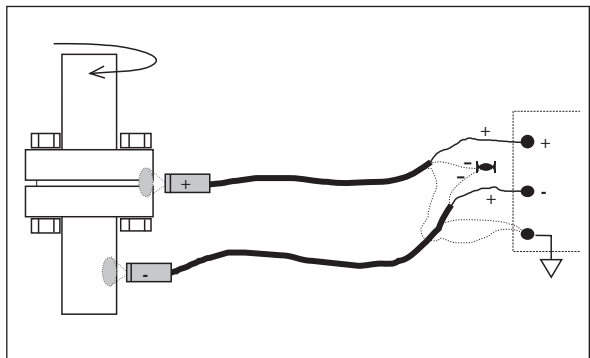

temperature between the joint and adjoining shaft. This difference is a direct measure of the heat created in the joint and will not be influenced by ambient temperature effects, since the differential pair arrangement cancels those effects. Accordingly, a very high precision can be achieved. An IRt/c with built-in air purge is recommended if the environment is oily or dusty.

Monitoring Tire Temperature for Racing Performance

Tire temperature is of critical concern in automotive racing for two reasons: the tire temperature directly affects its adhesion and its wear characteristics, and tire temperature patterns provide valuable information on the set-up and performance of the suspension.

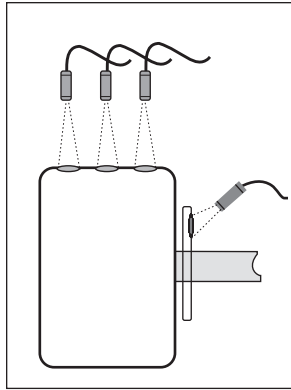

Use three sensors for profiling, one sensor for brake rotor.

For example, excessive loading of a tire caused by out-of-tune suspension will cause that tire to become considerably warmer than the others.

The IRt/c has proven to be an ideal measuring device for on-board data acquisition,

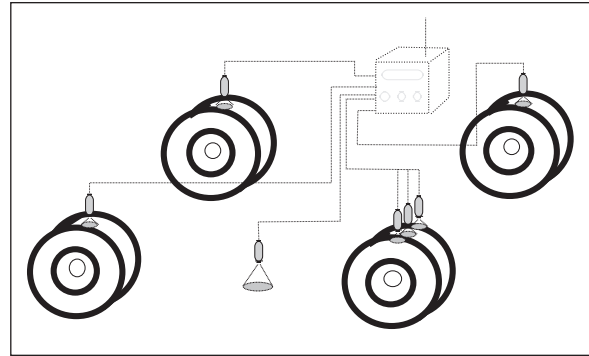

due its small size, ruggedness, and low cost. It may be connected to standard thermocouple read-out systems. Installation should include connecting the shield to a suitable ground in order to avoid interference from the electrically harsh environment of a racing automobile. Mechanical installation should include attention to air flow patterns to minimize dirt building on the lens. The IRt/c.3x or .5 are recommended because their narrower field of view allows them to be positioned further away

Multiplexed Datalogging Applications

An occasional problem introduced by switching-type thermocouple dataloggers is signal offset caused by the switching transient. The IRt/c is a completely passive device and produces an electrical signal entirely via thermoelectric effects, but does contain both resistance and capacitance above the levels found with conventional thermocouples. Many interface devices generate a small leakage current, which induces no shift in signal with conventional low impedance (<100 ohm) thermocouples, but may induce an offset with the higher IRt/c impedance (~3K ohm). This type of offset is normally stable and is simply calibrated out by adjusting the device's OFFSET or ZERO adjustment.

However, switching the thermocouple input can also cause offsets in IRt/c readout due to the presence of capacitance, if the signal leads are connected in a differential fashion to the amplifier input. A switching transient voltage stores a charge in the capacitance, which can cause the equivalent of leakage current offset. This offset could also be calibrated out, but may not be stable. A preferred method is simply to ground the negative side of the t/c input as shown.

The ground provides a path for the charge caused by the switching transient to dissipate, thus eliminating the offset. The twisted shielded pair wire with shield connected to ground will compensate for any loss of noise rejection, and thus provide a clean signal.

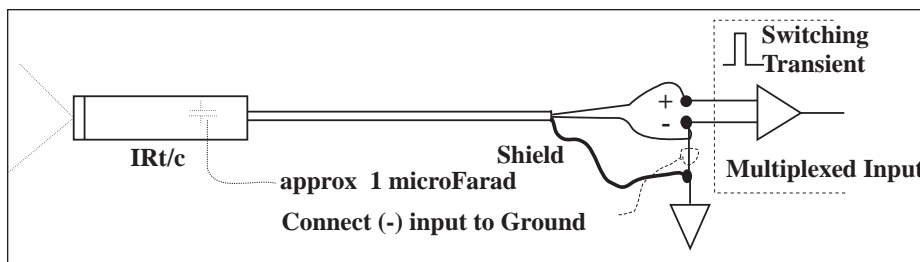

Air Purging is Recommended When Using Water Cooling

Tech Note

15

Very often the environment inside an oven contains vapors from the process which may condense on cooler surfaces inside the oven. When an IRt/c is used inside the oven to monitor the temperature of the process, the IRt/c must be cooled if the environment is above 212°F (100°C). Using the convenient IRt/c Cooling Jacket Kit available, either air or water may be used. For temperatures above 700°F (370°C) water is required, along with a small amount of purge air.

The IRt/c.3x is particularly suited for this service since the air consumption required to keep its lens clean is as little as .01 CFM (300 cc/min). A small convenient self-contained air pump is available.

The purge air has two important functions:

1. It keeps the IRt/c lens clear of vapors that would condense on its window, since the window temperature might be below the condensing temperature of some of the vapors of the process.
2. The internal convective heat transfer characteristics are optimal for cooling at very high environmental temperatures.

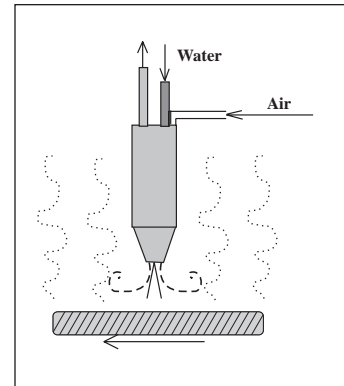

Why Offsets are Caused by Leakage Currents

Tech Note

16

Some thermocouple readout devices produce leakage currents which can create offsets when using an IRt/c. The current originates from two sources within the device: leakage current actually generated by the input amplifier, and leakage current intentionally injected to the thermocouple circuit to detect an open circuit due to wire breaks. These currents are normally of no consequence with conventional thermocouples with resistances < 100 ohms. However, with the higher resistance of the IRt/c (~ 3KΩ), devices with high currents will create offsets.

The offset calibration procedure presented in the IRt/c Manual is recommended for field use. For designers of readout devices, it is recommended that both sources of leakage current be reduced to 10 nanoamps or less to minimize offset errors. For recommendations on low offset readout devices contact Exergen.

As an extreme example, a device producing 1 microamp of current will result in less than one degree offset with an ordinary t/c with 10 ohms resistance. That same device reading an IRt/c at 3KΩ will produce an offset of the order of 100°F (55°C). Most readout devices have considerably smaller leakage currents and consequently smaller offsets. As a general rule, the smaller the offset the better, and readout devices should be chosen accordingly if other factors are equal.

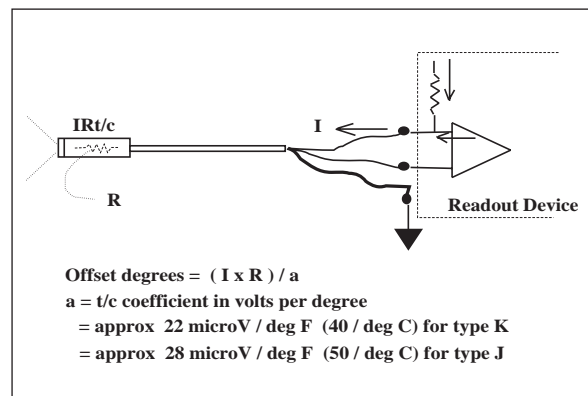

IRt/c's as Disposable Infrared Sensors

Destructive testing is commonly used in a number of industries, including, for example military weapons testing and fire safety testing. Thermocouples are routinely used for temperature measurement, and are connected to telemetering equipment to transmit the data before the sensor is destroyed in the test. Infrared would be preferred for a number of these measurements because of speed, convenience, and non-contact capability, especially in measuring the radiant temperature. However, the cost, complexity, and general fragility of conventional IR systems have made such applications impractical and prohibitively expensive.

The IRt/c, however, is ideally suited for this type of service.

Its compatibility with thermocouple telemetering devices, small size, ruggedness

of construction, and overall reliability makes it an excellent replacement for standard thermocouples. At one-tenth the cost of most conventional IR devices, it is economical enough to be used in "disposable" applications.

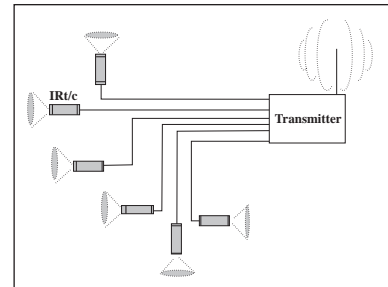

Detecting Hot Melt Adhesive in Product Assembly, Packaging

Much of the production of modern society is held together by means of adhesives, and without on-line inspection equipment, modern high volume production machinery can quickly fill a warehouse with improperly bonded scrap. Hot melt adhesive is probably the most widely used because of its solvent-free operation, high setting speed, and economy of use. With upwards of 100,000 hot melt "guns" in operation, there are many thousands of installations that can benefit from on-line inspection.

Hot melt bonding power is a function primarily of hot melt quantity and temperature. The more adhesive applied, the greater the area bonded. The hotter the adhesive, the less viscous it is - it becomes better able to "grip" the substrate material. However, if the hot melt is too hot, it chars, forming a residue which plugs the injection nozzles of the guns. Non-meltable contaminants also enter the melting system at times. These contaminants also eventually clog the nozzle or filters. Either way, the adhesive flow is blocked and poor product is produced.

A pair of IRt/c's, wired differentially (connect the minus leads together and measure across the plus leads) reliably detects the infrared energy radiated by the adhesive. This heat energy is proportional to the amount and temperature of the adhesive it sees,

which in turn is an excellent indication of the hot melt bonding power. Wired differentially, one IRt/c will give a (+) response to heat, while the other will give a (-) response to heat.

Fixture the (+) IRt/c to view the adhesive shortly after it is applied by the gun. Fixture the (-) IRt/c to view an area of the substrate in which there is no adhesive. The (-) IRt/c is called the Reference, since it automatically compensates the (+) unit for any changes in substrate temperature, such that the net signal provided by the IRt/c pair is created only by the net heat of the adhesive being added to the substrate (the hot melt being applied properly to the carton, etc.).

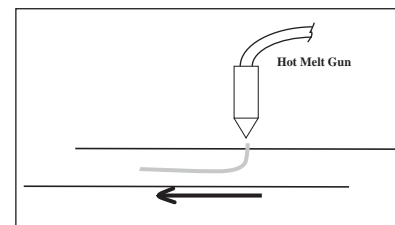
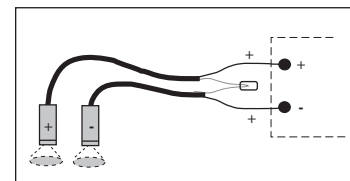

continued...

The Reference IRt/c is a very powerful tool. It can be located next to the (+) IRt/c for corrugated carton, on the under side of a plastic base cup while hot melt is applied to the top, or upstream of a coating head with the (+) downstream. The differential pair of IRt/c's will reliably report the presence or absence of hot melt compared to a reference area by the presence or absence of the characteristic heat signature. With set-up calibration, the pair of IRt/c's will also indicate quantitatively how much hot melt is being applied.

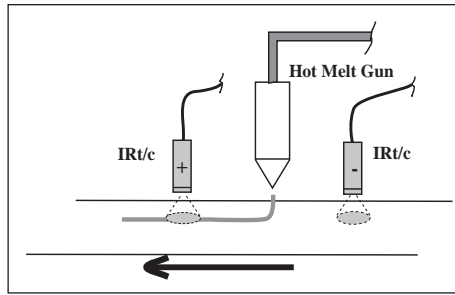

The IRt/c.3x is usually the model of choice due to its smaller tip, narrower field-of-view, and built-in air purge for dirty environments, but any of the IRt/c models may be used. The output signal from the differential pair is in the range of 1 millivolt for a typical set-up. Any suitable amplifier can be used.

fixture in order to minimize any thermal differences between them.

Set up and operation involve fixturing the IRt/c's at the desired inspection points, operating the adhesive applications at the minimum acceptable adhesive level, then adjusting the alarm limits to that level.

Since the IRt/c's are measuring differentially, no cold junction compensation is required, and might cause errors if present. The amplified signal can be interfaced by computer, PLC, or other control device. Be sure to "design in" adequate sensitivity adjustment. For best performance, it is recommended that both IRt/c's are mounted in a single aluminum

How the Pit Viper Measures Infrared Radiation

Tech Note

19

Like the IRt/c, the pit viper has the ability to "see" infrared radiation.

Pit vipers comprise a family of snakes that share a sophisticated thermal adaptation that stems from the evolution of specialized pit organs located near their eyes. These organs sense the infrared radiation of an approaching warm-blooded animal and send signals to the snake's brain. These signals are used with the visual picture provided by the snake's eyes, giving the snake more complete information about its environment.

Pit organs are small facial cavities covered by a thin membrane of sensory cells that respond to temperature differences between the target and the snake's body temperature. These sense organs are so sensitive they can resolve differences of just .003°C. Pit vipers can detect the presence of a warm-blooded animal at distances of up to 50 centimeters in total darkness simply from the animal's infrared radiation. The pit viper quickly and accurately scans the target with its infrared-sensing pit organs before deciding to strike to defend its nest or attack its prey.

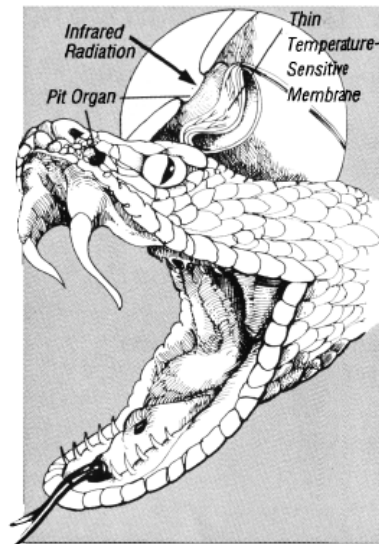

The non-contact temperature capability of both the pit viper and the IRt/c provides the survival edge in a fiercely competitive environment.

Relative Humidity Measurement

IRt/c's can be used to accurately and reliably measure actual relative humidity in many situations where there is a convenient source of water and flowing air.

An IRt/c aimed at a wet porous surface with ambient air blowing across the wet surface can actually measure what is called "wet bulb" temperature for that ambient area. (More precisely, wet bulb temperature is the equilibrium temperature of the air-water interface when a water film is evaporated. When air is moved over a wet surface, the water cools by evaporation until it reaches wet-bulb temperature, then the cooling stops, no matter how much more air is moved over the surface. The temperature at which the cooling stops is the wet bulb temperature.)

The IRt/c measures the temperature of the air-water interface on a surface directly. The quality of the water or of the absorbing material does not affect the reading, since the IRt/c can directly view the air-

water interface, and the wet bulb equilibrium temperature is not materially affected by impurities.

The highest precision method is to employ an IRt/c wired differentially with a conventional thermocouple to measure the quantity "wet bulb depression". The differential pair arrangement guarantees high accuracy, since RH is a strong function of wet bulb depression and a weak function of dry bulb temperature. Standard psychrometric tables, charts, and software algorithms can be used with the data to obtain accurate relative humidity for your environmental measurements.

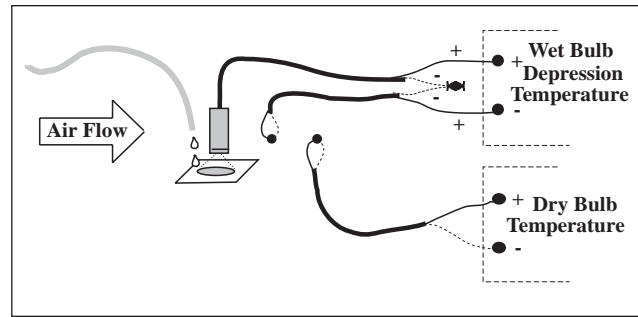

Controlling Web Roller Temperature

The IRt/c infrared thermocouples have quickly become the sensors of choice for monitoring and controlling both web and roller temperatures. Here are some tips on accurate roller temperature measurement.

1. Uncoated Metal or Chrome Rolls

Shiny, uncoated metal rolls are a difficult surface for any infrared temperature sensor to properly measure, because the sensor will see too many environmental reflections. The solution is to simply paint a small black stripe on an unused end of the roller. Aim the IRt/c sensor at the black paint stripe. It will then measure the temperature accu-

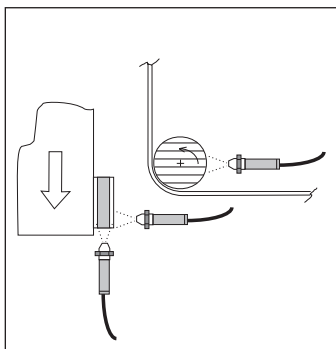

rately and reliably regardless of changes in the surface conditions of the rest of the roller.

rately and reliably regardless of changes in the surface conditions of the rest of the roller.

If there is very little space on the edge of the roller, move the sensor closer and paint a very small black stripe. The minimum spot size of the IRt/c is 0.3 inches (8 mm), and for the IRt/c.3x it is 0.25 inches (6 mm) when the sensor is brought close to the surface.

2. Dull Metal Rollers

Dull metal rollers can provide a reliable signal. However, it is best to test the surface, as the surface emissive properties may be changed by dirt, moisture, cleaning, etc. When in doubt, it is best to simply paint a stripe to eliminate these variations.

3. Non-metallic Surfaced Rollers

These will provide a reliable IR signal at any point the IRt/c is aimed. No painted stripe is required.

Controlling Vacuum Forming and Thermoforming Processes

Tech Note

22

For forming plastics, radiant heat with an IRt/c is an excellent combination of heating method and control. They work extraordinarily well together, since both the heating and measuring occur right at the surface, where the plastic is located. The IRt/c reading is unaffected by reflections from the heater, since the spectral response of the 6 to 14 micron IRt/c lens filters out the shorter wavelengths of the radiant heater energy.

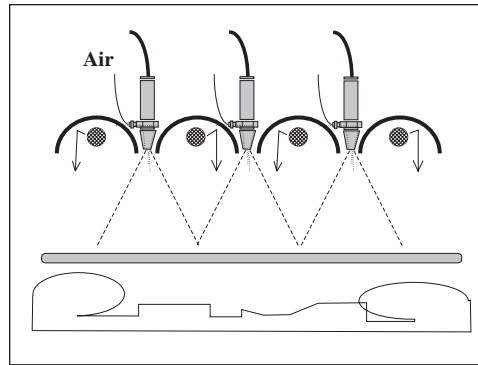

Select any of the IRt/c models, depending on the field-of-view required to see past the elements to the painted surface. Care should be taken in mounting the IRt/c in such a way as to keep its temperature below 200°F (93°C) and to keep the lens clean. The IRt/c.3x is the preferred model for this application because of its small physical size and built-

in air purge. It can be used in temperatures up to 250°F (121°C) when the air purge system is used. For still narrower fields of view, the IRt/c.5 and IRt/c.10 with 5:1 and 10:1 FOV respectively are very popular.

The IRt/c may be mounted in between ceramic heaters, or in the shroud or reflector of the radiant heater, such that it can see in between the ele-

Controlling Printed Circuit Board Preheat During Wave Soldering

Tech Note

23

The IRt/c is an excellent solution to the problem of heater control for PC board preheat. IRt/c's work particularly well in this process, since both the heating and measuring occur right at the surface, where the solder must flow. The IRt/c reading is unaffected by reflections from the heater, since the spectral response of the 6-14 micron IRt/c lens filters out any shorter wavelengths of the radiant heater energy.

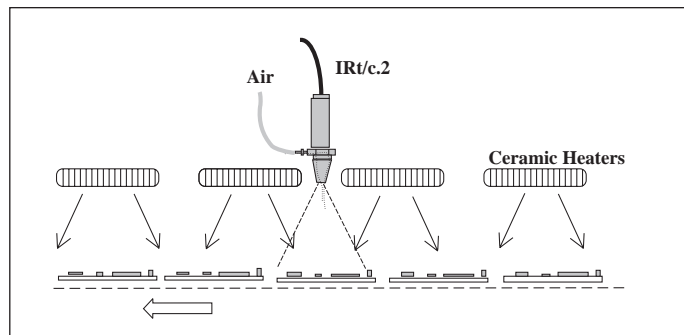

The IRt/c may be mounted in between ceramic heaters, or in the shroud or reflector of the radiant heater, such that it can see in between the elements. Select the IRt/c model with the field-of-view required to see past the elements to the PC boards. Care should be taken in mounting the IRt/c in such a way as to keep its temperature below 200°F (93°C) and to keep the lens clean. The IRt/c.3x is the preferred model for this application because of its small physical size

and built-in air purge. It can function in temperatures to 250°F (121°C) when the air purge system is used. For still narrower fields of view, the IRt/c.5 and IRt/c.10 with 5:1 and 10:1 FOV respectively are very popular.

IRt/c Controls Product Drying (Paper, Wood, Textiles, Film)

In processing of products such as paper, wood and textiles, it is important to be able to determine quickly when the products are sufficiently dry.

The surface temperature of a "wet" product will change (rise) very slowly as constant heat is applied to the product. This occurs because the moisture in the product absorbs much of the heat energy as it evaporates. At the point that the product becomes "dry", however, the same constant heat supply will quickly raise the temperature until it reaches the same as the surrounding air, or higher if the heat source is radiation. If temperature vs. time is plotted for a heated drying process, the target "dry" temperature point can clearly be seen as the beginning of a rapid rise in surface temperature.

IRt/c's can be used to monitor these changes in surface temperature. With their fast 0.1 second response time, IRt/c's can quickly detect when the surface temperature begins to rise rapidly, an indication that the products have reached a low moisture content. (See also Tech Note No. 67)

A simple implementation method is to measure the difference in temperature between the product and the ambient air. Determine the delta T that results in the correct dryness, and set the control system to maintain that delta T.

The IRt/c is particularly convenient because it can be wired differentially with an ordinary thermocouple.

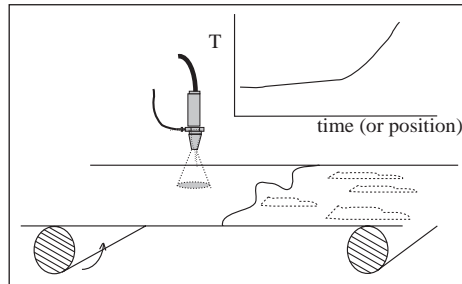

The combined signal can be fed to a single control channel. Alternatively, if absolute temperature is preferred, the IRt/c and thermocouple can be read and controlled independently.

For hot, humid, dusty environments, the IRt/c.3x is recommended because of its small size and super-efficient purge air system.

Fully developed, patented IRt/c-based drying systems are available. Contact Exergen for referrals.

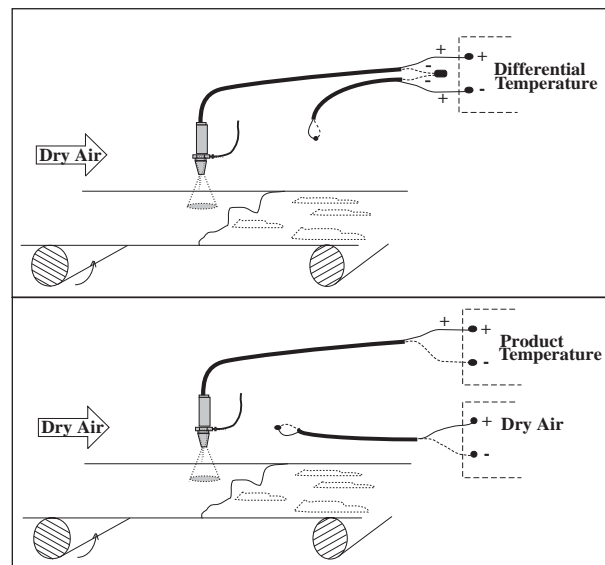

Cooling Jacket Kit for Environments to 1000°F (540°C)

A convenient and inexpensive kit makes it possible to use either the IRt/c or IRt/c.3x with air, water, or both for service in harsh environments. Measuring only 4.16" x 1" (106 x 25 mm) overall, the CJK-1 is physically small enough to fit into tight areas and closely monitor process temperatures from the optimum position - up close. With its all stainless steel housing, it can withstand the harshest environments.

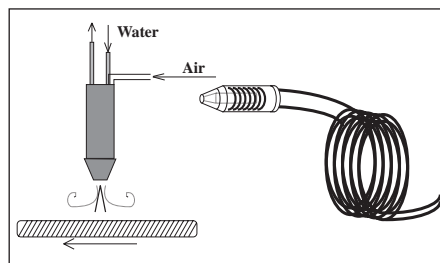

Extraordinarily efficient in design, the CJK requires only .05 gpm (190 cc/min) to protect an IRt/c at 1000°F (540°C). A small amount of air purge insures that optimum cooling is maintained, and prevents condensation on the lens (see Tech Note No. 15).

The water cooling system consists of a seamless monotube, in order to eliminate the possibility of leaking joints. For convenience, the seamless tubing includes an extra 3 ft (1 m) tubing length.

IRt/c Repeatability and Long-Term Accuracy

Tech Note

26

The ability of the measuring device to maintain its calibration under service conditions and over a long period of time is of fundamental interest in temperature control. The IRt/c is rated at less than 0.1°C repeatability and has no measurable long term calibration change, which makes it well suited for reliable temperature control. These attributes are inherent in the basic design and construction of each IRt/c.

Repeatability is defined as the ability of a measuring device to reproduce its calibration under identical conditions. The IRt/c is a solid, hermetically sealed, fully potted system that does not change mechanically or metallurgically during service. There are no active electronic components and no power source to produce the signal – only the thermoelectric effects that produce a thermocouple signal.

Long term accuracy is influenced by the same things that influence repeatability: mechanical changes and metallurgical changes. It is well known that thermocouples can change calibration over time due to these effects.

Mechanical changes occur because conventional thermocouples are generally constructed as small and light as possible to enhance response time, making them vulnerable to deformations that can change the thermoelectric properties. More importantly the conventional thermo-

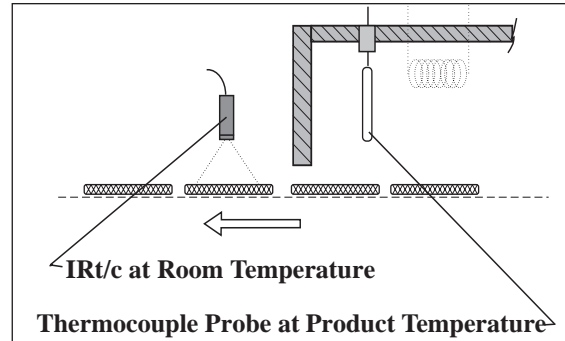

couple must operate at elevated temperature since it merely measures its own temperature.

The metallurgical changes which affect thermoelectric properties are a strong function of temperature; they are negligible at room temperature, but are of serious concern at high temperature.

The IRt/c solves both problems by its design and basic operation. Its solid fully potted construction in a mechanically rigid stainless steel housing, and operation at near room temperature conditions, essentially eliminate the classical drift problems of conventional thermocouples. Every IRt/c is double annealed at temperatures above 212°F (100°C) to ensure long term stability, and tested five times prior to packaging. Barring a small percentage of failure, the IRt/c has essentially unlimited long term calibration accuracy.

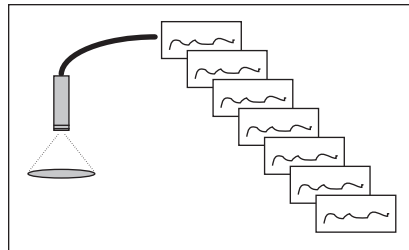

Tech Note

27

Air Pump Accessory Keeps IRt/c's Clean and Cool

For IRt/c installations in which a purge air source is not convenient, or is too expensive to install, the IRt/c Air Pump Kit is ideal. The air pump is rated for continuous duty and produces 120 cubic inches/minute (2000 cc/min) air flow, which is more than sufficient for purging; and will cool an IRt/c.3x in environments up to 240°F (115°C). The pump is available in both 120 VAC and 12V DC versions, and is supplied with 10 ft (3 m) of vinyl tubing, and horizontal/vertical mounting system.

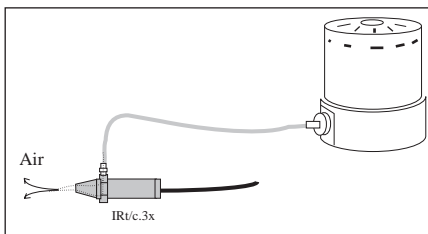

The Air Pump Kit is recommended for installations in which dust, dirt, or vapors are present which might coat the IRt/c lens, or for situations in which long term operation has been a problem due to fouling of the lens. At less than \$100; requiring only a few

minutes to install; and its small 5" x 3.3" (13 x 8 cm) size; the Air Pump Kit provides you a convenient and inexpensive assurance of long term, trouble-free operation of your IRt/c temperature control system.

IRt/c Trouble Shooting Guide

There are only three possible failure modes for an IRt/c sensor. If an IRt/c sensor is installed and does not function as expected the failure may be due to something other than the sensor. It is recommended that the sensor is checked out for response after installation to ensure that it is connected to the readout instrument properly. This can be done simply by placing a hand or a heat source in front of the sensor after it is installed and making sure the reading changes (this is still valid even if the temperature is well below the calibration point).

If the sensor gives a reading very different from the expected reading:-

1. Check initial calibration. If the controller has been changed, or the offset adjusted after the sensor has been installed, the temperature reading may be very different from the actual temperature.
2. Check the sensor lens. If dirt has accumulated on the lens over time, then the reading may be lower than expected. Clean the lens using a Q-tip and alcohol. The lens needs to be treated gently, it can be easily scratched.
3. If the sensor reading does not change even though the target temperature is changing, the sensor may be burnt out. Check the impedance of the sensor, if the impedance is >15kohm, then the sensor is probably burnt out. If the impedance is <100ohm, then there is a short in the thermocouple wire and the temperature being measured is at the short.
4. If the temperature suddenly reads about half of what it should, then the hermetic seal may be compromised and the Xenon gas may have escaped.

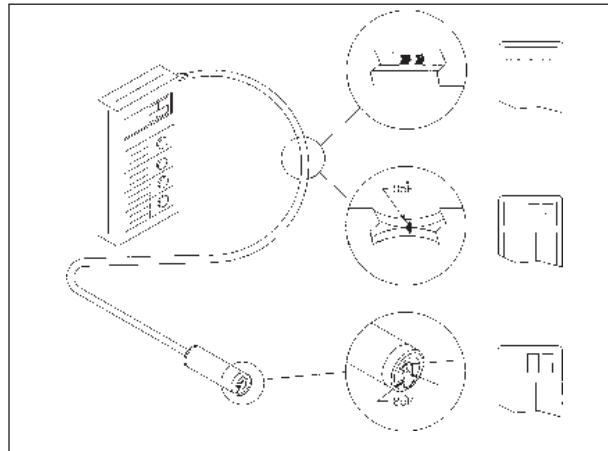

Symptom	Action	Result
1) Sensor reads high	Check initial calibration	Adjust zero offset of readout to bring reading back to normal.
2) Sensor reads low	Clean lens of sensor	If sensor does not correct, check points 3 and 4 below.
3) Sensor reading does not change	Check impedance of sensor	If sensor reads open, replace. If sensor has impedance of a few 10W, then there is a short in the t/c wire.
4) Sensor reading suddenly drops by about half	Check through points 1 to 3 above	If still reads low, replace sensor.

For more information regarding the calibration testing of IRt/c sensors, see Tech Note #74. For process control applications, the system can be programmed to check the sensor circuit every time it is powered up, see Tech Note #39.

If a PLC is used for process control, a sensor short will have the same effect as a "Heater Burn Out Protection" feature.

IRt/c Can Measure Obliquely

Tech Note

29

Often, an area needs to be temperature monitored, but because of space limitations, the IRt/c cannot be placed to view the target area squarely. In such situations the IRt/c can be angled obliquely to view the target area. The field-of-view then becomes elliptical instead of circular, and the IRt/c averages the temperature it sees.

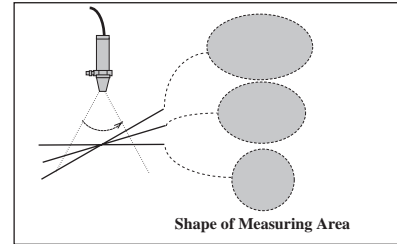
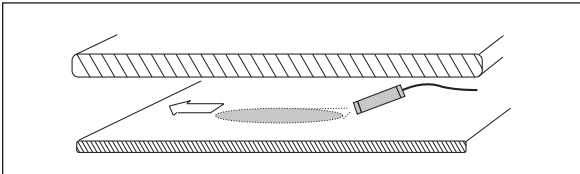

To apply this method, be sure to estimate the size of the field-of-view footprint, and confirm that the IRt/c is measuring the area you wish to measure.

IRt/c Measures Vibrating Objects

Tech Note

30

Measuring the temperature of objects that are nominally stationary, but vibrate, can be a difficult problem because of mechanical fatigue of any contact device. An example is continuous monitoring of the casing temperature of both the turbine and compressor side of a turbo-charger. Thermocouples or other contact devices fail after only a few hours due to the high frequency vibration present during turbocharger operation.

The IRt/c provides a simple and inexpensive solution. Mounting the IRt/c's to a non-vibrating surface, they can monitor the turbocharger temperature without being subject to the destructive vibration.

Wherever there is a requirement for machinery monitoring, temperature should be included; and for machines that vibrate, the best solution is the IRt/c.

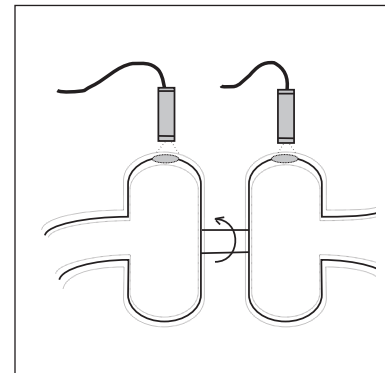

What is Emissivity?

Tech Note

31

Emissivity is a surface property which determines how much radiation an object emits at a given temperature compared to a blackbody at the same temperature. Emissivity (along with background thermal radiation) is a primary source of errors in infrared temperature measurement. Emissivity can be more easily understood if it is realized that infrared has similar properties to visible light.

Mirrors figure prominently in the discussion of heat radiation and emissivity*. Since heat and light radiation behave similarly, what we see with our eyes is similar to what the IRt/c sees.

When you look in a mirror with your eyes, you see only reflections, nothing of the mirror itself. If the mirror is perfect, it has 100% reflectivity. Therefore, it emits nothing because it reflects everything. For this condition, the emissivity is zero.

If we consider an imperfect mirror, the eye then sees mostly reflection, but also some of the imperfections on the mirror surface. If, for example, we saw 90% of the mirror as a perfect reflector and 10% as imperfections, 90% of the mirror would reflect; the remaining 10% would emit. Therefore, the emissivity equals 0.1.

continued...

Why the D-Series is Recommended for IRt/c Temperature Control Calibration

Because of its speed, accuracy, and its patented Automatic Emissivity Compensation System (AECS).

As in all infrared temperature control systems, IRt/c installations should be calibrated to the characteristics of the materials and the process being controlled, in order to insure that the control temperature is accurate. Accordingly, the calibration reference must be selected such that its accuracy is independent of the variables that influence the temperature control accuracy. In the case of infrared temperature control, the major variables are emissivity and ambient reflections.

The Microscanner D-Series has the necessary accuracy and independence from emissivity and reflection errors, due to its AECS feature. The reflective cup configuration of the sensing head automatically corrects for emissivity by creating a tiny blackbody at its point of measurement. By "trapping" the emitted radiation, and excluding the ambient radiation (thereby replacing the reflected ambient radiation with reflected *emitted* radiation) the sensing eye sees a blackbody; and thus can report the temperature precisely.

The result of AECS is illustrated below.

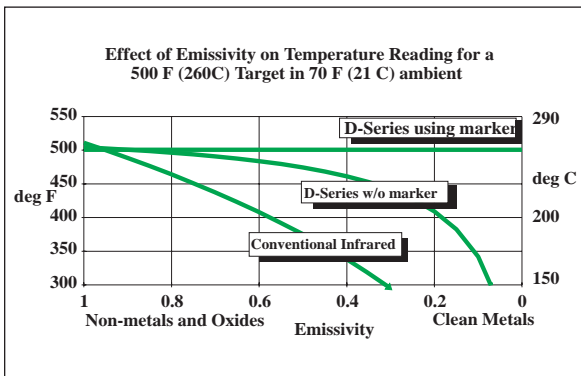

Conventional infrared devices are strongly influenced by both emissivity and ambient variation, while the D-Series remains accurate.

Additional factors in calibration accuracy are speed and contact error when using conventional thermocouples. The D-Series overcomes both problems, and makes it possible to complete the temperature control set-up very quickly and accurately.

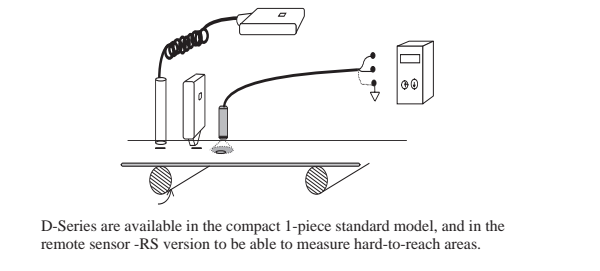
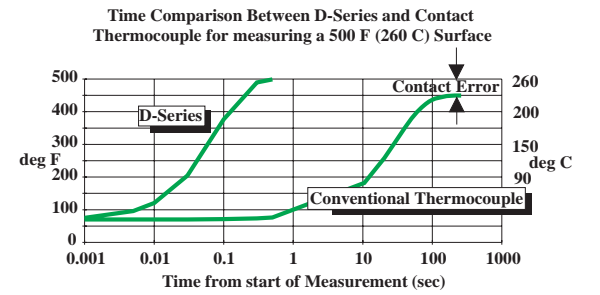
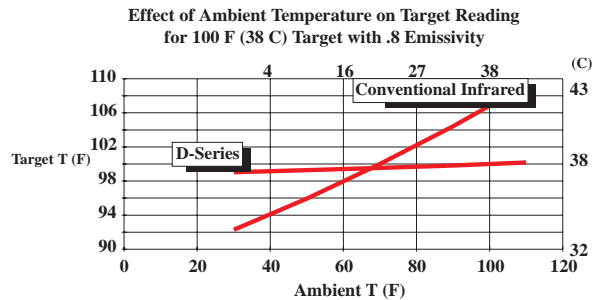
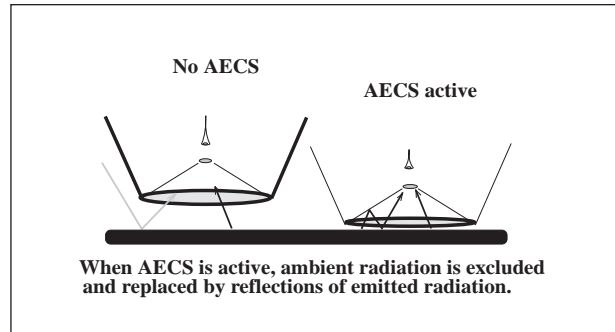

For further information on Exergen's Microscanner D-Series Infrared Scanner/Thermometers call or fax Exergen or your local Authorized IRt/c Distributor.

Checking IRt/c Ambient Temperature

In many installations, it may not be clear whether cooling is required, and it may not be easy to obtain the temperature of the environment experienced by the IRt/c. The IRt/c itself will tell you what its own temperature is, by using the procedure illustrated below.

The basic method is to temporarily "blind" the IRt/c using aluminum foil, so that it can only see itself. The temperature that it produces is then its own temperature only.

Before running this test, be sure to check for leakage current offsets as described in the manual.

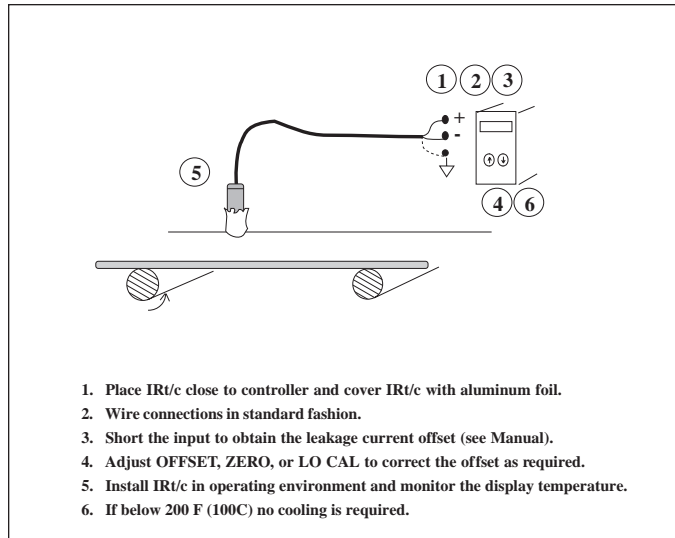

Air Purge and Air Cooling Requirements

The limiting air flow restriction for all of the IRt/c models and Cooling Jacket Kit is the air fitting supplied with the unit. Accordingly, all IRt/c's with built-in air purge, and the Cooling Jacket Kit (CJK-1) all have essentially the same pressure vs. air flow characteristics, and the air flow chart applies to all. However, the air consumption requirements for purging or cooling for each are somewhat different due to size and operation variables. Refer to the table or chart for specific model requirements for minimum pressure for purging, or for cooling in elevated ambient conditions. IRt/c.xxx refers to all models with the 1.375" (34.9 mm) housing diameter. If water cooling is used with the Cooling Jacket Kit, air purge pressure only is required.

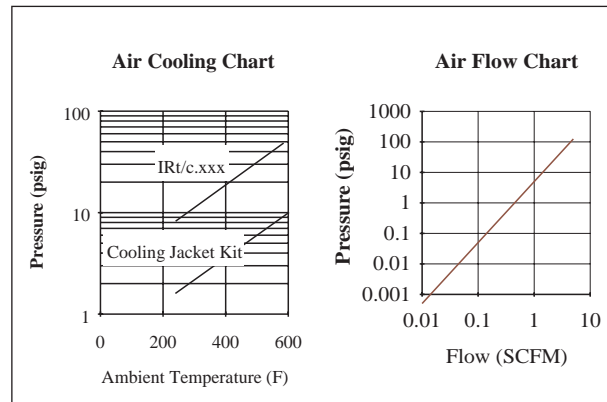

To convert to metric units the following may be used:

deg C = (deg F-32) x (5/9)
kPa = psig /.15
SCFM/35

Model	Air Purge Pressure
IRt/c.3x	> 0.1 psig
IRt/c.xxx	> 5 psig
Cooling Jacket	> 0.1 psig

Large Diameter Reflective Cup Used for Silicon Wafer Temperature Measurement

Tech Note
36

Silicon wafer fabrication involves many operations, most of which require the accurate determination of the temperature of the silicon. The surface temperature is an essential control variable for efficient high quality processing of material.

As the wafer is processed the emissivity of the surface can vary considerably due to the different properties of the substrate layers. To enable the accurate rapid measurement of the wafer temperature, a reflective cup was developed. The reflective cup prevents ambient radiation from entering the sensor and replaces it with reflected emitted radiation. By reducing errors caused by ambient reflections and emissivity variations the measurement error can be reduced by about a factor of ten.

The IRt/c.1X is a good sensor to use for this application, it is small and can easily be mounted to the reflective cup.

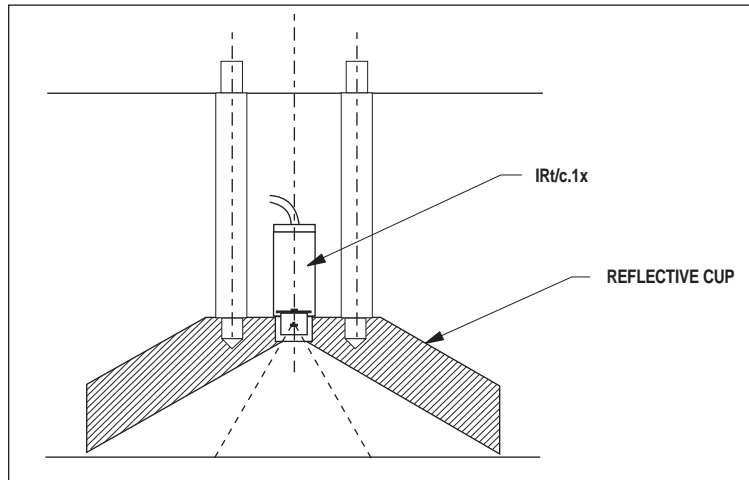

Selecting Temperature Controllers

Tech Note
37

IRt/c infrared thermocouples are designed to be used with all thermocouple readout devices and controllers, but due to the higher impedance levels of the IRt/c compared to standard t/c's, some controllers are better suited than others. Leakage current generated by the controller (see Tech Note #16) creates an offset in reading which should be adjusted out for accurate temperatures. If the offset produced by the leakage current is larger than the available offset adjustment of the controller, the IRt/c will still produce repeatable readings and

control accurately, but the temperature indication will be incorrect. Accordingly, recommended controllers are those which have low leakage currents and/or sufficient offset adjustment to produce an accurate IRt/c reading (see chart for relationship between leakage current and offset).

Following is a list of controller manufacturers with models known to have low leakage currents and are recommended for use with the IRt/c:

Athena, Cal Controls, Eurotherm, Fenwal, Fuji, Honeywell, Love, Newport, Omega, Omron, Partlow, Red Lion, Syscon, Watlow, Yamatake-Honeywell, Shinko Technos

This list is not a comprehensive one - manufacturers are constantly improving their models. Contact your local Authorized IRt/c Distributor for specific models, or the controller manufacturer to inquire as to suitability of specific models for service with an IRt/c (sensor impedance of ~5KW).

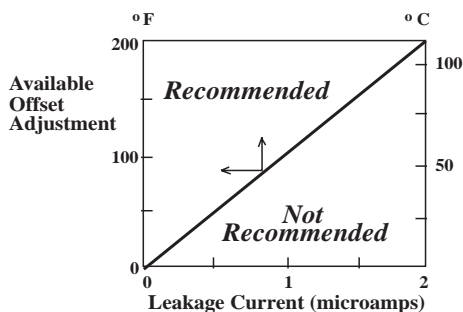

How the IRt/c is Manufactured for Reliability

The IRt/c is designed and manufactured to provide a lifetime of reliable operation in the most demanding service conditions. To assure this performance, every IRt/c is put through a rigorous process of manufacture, including seven separate test stages. At the end of this process, the IRt/c is ready to be installed, and is ready to provide you with reliable infrared temperature data for many years.

As an additional reliability feature, all IRt/c's are manufactured with a Xenon gas fill hermetically sealed into the sensing system. If the hermetic seal is broken by mechanical or thermal damage to the sensor, the Xenon immediately escapes, and the IRt/c radiation sensitivity (difference between target and sensor temperature) immediately drops by more than a factor of two, thus providing an obvious indication of failure, rather than a gradual change which can cause poor quality service for a long period of time before a failure is detected.

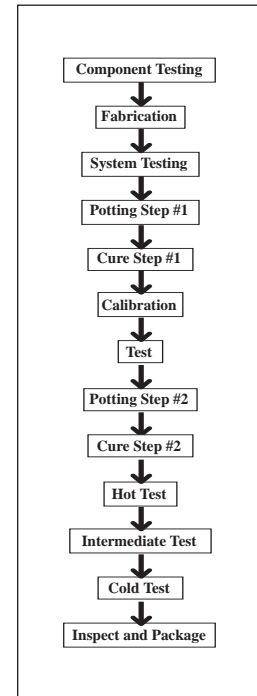

A Software Method of Self-Testing IRt/c's

For many OEM applications, it is important to be able to test the IRt/c for proper operation each time the system is started, assuring the user that all systems are functioning, much the same way that a microprocessor can be programmed to check itself when powered up. This feature is especially useful to check for cleanliness of the lens in applications where a user might inadvertently spill something on its surface.

The test is performed by applying a known power input to the target to be heated, and monitoring the initial rate of change of temperature of the target as seen by the IRt/c. ***This rate of change is dependent only on the power level and independent of the initial temperature of the target, as long as the target began at a uniform temperature.*** Sufficient time must be allowed after the previous powerdown.

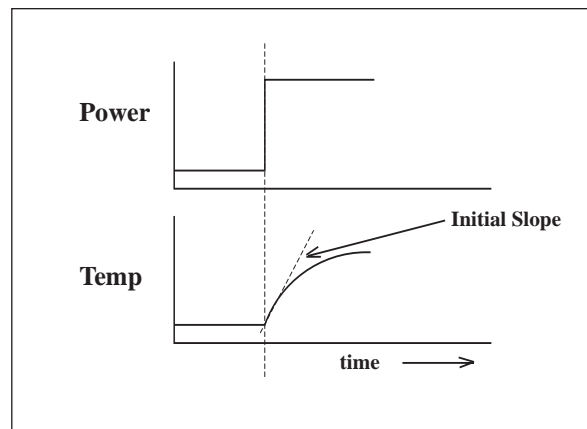

If the IRt/c is clean and functioning normally, it will report the correct rate of change, and the machine becomes operational. If the rate of change is lower than normal, the user is alerted to clean the lens. If this still does not produce the desired response, service is required on the IRt/c or heater, target, control, etc.

Monitoring Plastic Extrusions

Tech Note

40

IRt/c's are well suited for monitoring the temperature of plastic extrusions, either at the point of extrusion to monitor correct extrusion temperature, or after air cooling to monitor/control the cooling process prior to cutting to length. The model recommended depends on the monitoring geometry.

For extrusions of 1" (2.5 cm) width or more, the standard IRt/c may be used at a distance of 1/2" (1.3 cm), which is sufficient to keep the lens clean in a reasonably clean environment.

For smaller extrusions, or for up-reading; the IRt/c.3x is preferred due to its smaller 0.25" minimum spot size (6 mm), and built-in air purge, which will maintain cleanliness even when very close to the hot plastic and pointed up.

For larger extrusions, in which more convenient positioning at greater distance is desired, the IRt/c.5 is recommended, due to its narrow 5:1 field-of-view.

For the smallest extrusions, the "Slot Spot" models, with their tightly focused optical systems, can measure to 2 mm (see Tech Note No. 80).

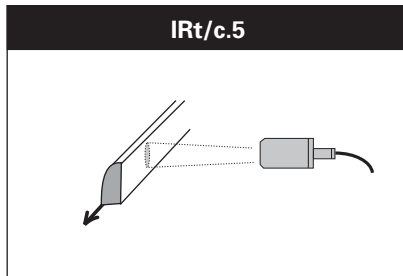
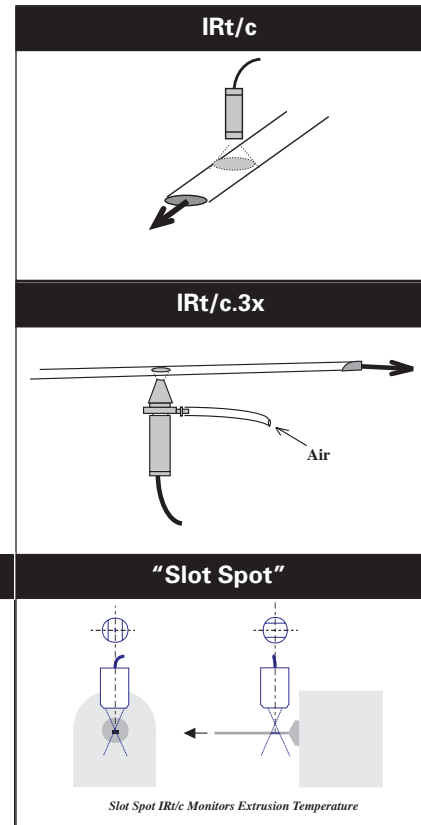

IRt/c.5 Has 5:1 Field-of-View and Built-in Air Purge

Tech Note

41

The IRt/c.5 model extends the range of applications for infrared thermocouple thermometry to situations where geometry requires that the sensor be mounted remotely from the target. In addition to the narrow 5:1 field of view (11° included angle), this model retains all of the ruggedness and elegant ease-of-use features of the original IRt/c models, is hermetically sealed, and is equipped standard with an internal air cool/purge system. As do all IRt/c's, this new model exceeds all applicable NEMA standards, and is intrinsically safe.

Specifications (where different from other models):

Sensing Range: -50 to 1200°F (-45 to 650°C)

Field of View: 11° approx. (5:1)

Minimum Spot Size: 0.8" (2 cm)

Output impedance: 4 KW to 8 KW, varies by model

Weight: 6.5 oz with cable (184 gm)

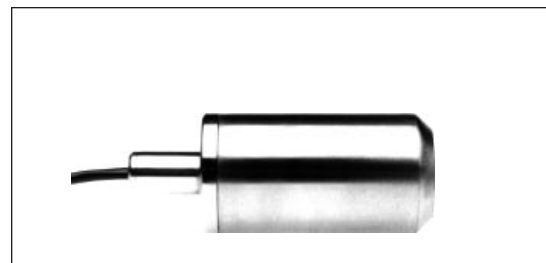

For drawings indicating field of view, mounting, air purge path, etc., see the Catalog Section of this book.

Monitoring Dangerous Chemicals and Hazardous Environments

Handling, processing, or storage of certain materials involves an element of risk of fire, chemical damage, or explosion. Many times these materials are monitored using pyroelectric, air temperature, or ultraviolet devices to detect a fire situation, in order to activate alarms and extinguishing systems. These devices do not, however, provide the earliest possible indication of a problem, because they cannot detect the initial heat **prior** to the fire.

The IRt/c, however, is capable of detecting even the smallest temperature rise which must occur before a fire starts, and transmit the information in as little as 80 milliseconds to the thermocouple monitoring device, thus providing the maximum time to initiate extinguishing or cooling measures. The wide field-of-view standard IRt/c can average a wide area for broad coverage of heat build-up, or the narrower IRt/c.3x, .5, and .10 models can monitor specific areas from greater distances. Actual fire types and

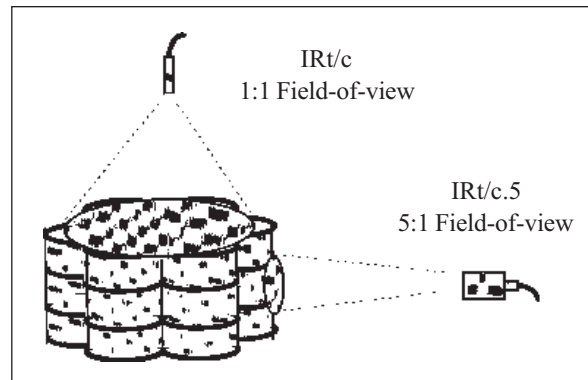

special conditions should be evaluated prior to applying IRt/c's.

As a "simple device" all IRt/c models are rated intrinsically safe (Tech Note #10), and as hermetically sealed devices meet or exceed all applicable NEMA ratings.

Bread and Pastry Dough Mixing Temperature

Measuring the temperature of bread and pastry dough while mixing is difficult at best with conventional contact thermocouple probes, due to breakage and possible contamination of the food. However, the temperature is quite important since too high a temperature will cause too much rise, leading to holes in the baked product, and too low a temperature will not allow the dough to rise sufficiently, resulting in a product that is flat.

The IRt/c solves the problem by monitoring temperature *without contact*, completely eliminating breakage and possible contamination. Wired into a temperature controller, the information can be used to control mixing speed motors to maintain proper dough temperatures.

The recommended models are the IRt/c.3X and .5, since their built-in air purge keeps the lens clean even in the dusty interior of the mixer. Hermetically sealed, the IRt/c can be washed down during normal cleaning procedures. The recommended mounting location is the lid of the mixer, where the IRt/c has a clear view of the dough, and swings out of the way when loading and unloading.

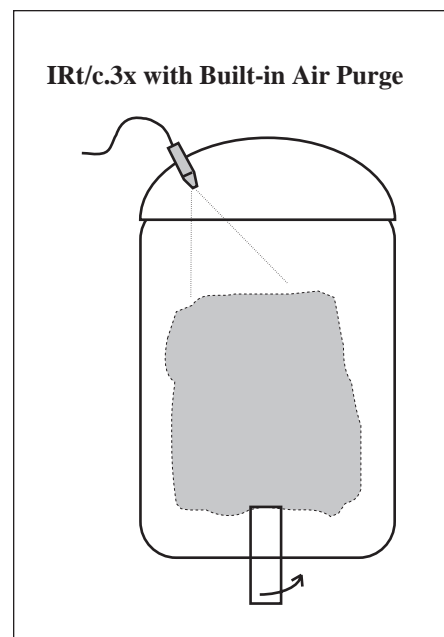

Induction Heater Control

Tech Note

44

The induction heating process can be readily controlled by the temperature of the part as measured by an IRt/c non-contact infrared thermometer. Several issues should be considered in an installation:

1. **The effect of the field on the IRt/c:** since the measuring signal is electrically isolated from the housing, the IRt/c will operate in even a very strong field. The shield wire should be attached to a proper signal ground. If there is excessive heating from the field, consider using the cooling jacket kit, with the same water source as is used to cool the coil.
2. **The field-of-view:** the preferred method is to view the part between the coil turns or from the end. Select the IRt/c model that best suits the requirements. For small gaps between coils, consider the focused models

3. **Part temperature:** IRt/c models can be used to measure target temperatures up to 5000°F (2760°C). Select the correct model for the control temperature desired.
4. **Part surface material:** For bare metal parts the *Lo E* models are recommended. For coated or non-metal surfaces the *Hi E* models should be used.

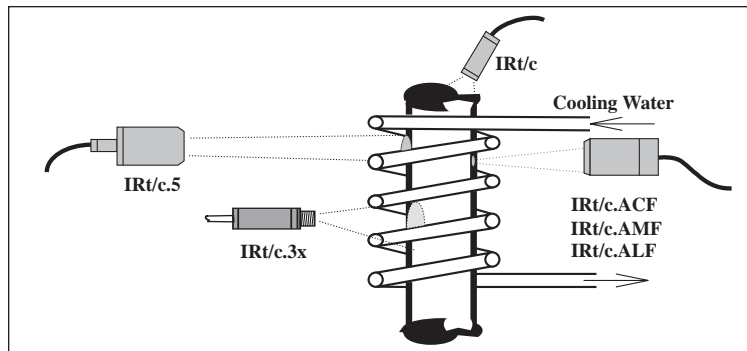

Printing/Ink Drying

Tech Note

45

For high speed printing processes, the limiting factor on productivity of the equipment is usually ink drying time. With non-contact monitoring of the inked surface temperature, press production can be maximized while assuring top quality.

The surface temperature of freshly inked paper will be considerably cooler than ambient air temperature, and will rise very slowly as the paper absorbs heat. This occurs because the ink solvent absorbs much of the heat energy as it evaporates. At the point that the product becomes "dry," however, the same constant heat supply will quickly raise the temperature until it reaches the same as the surrounding air, or higher if the heat source is radiation. If temperature vs. time is plotted for a heated drying process, the target "dry" temperature point can clearly be seen as the beginning of a rapid rise in surface temperature.

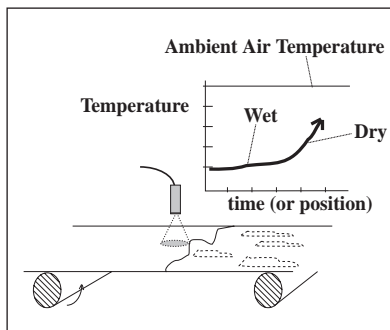

The IRt/c's can be used to monitor these changes in surface temperature. With their fast response time, the IRt/c's can quickly detect when the surface temperature begins to rise rapidly, an indication that the ink has dried, thus allowing press speeds to be maximized. Since all IRt/c's are rated intrinsically safe (see Tech Note # 10), and are hermetically sealed to meet or

exceed all applicable NEMA ratings, they can be used in hazardous environments with alcohol-based and other volatile inks. For tight areas, the IRt/c.SV or IRt/c.3SV is recommended.

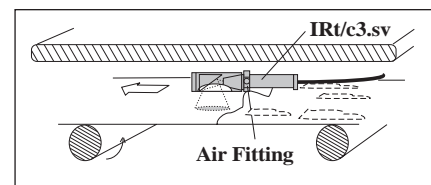

Discrete Parts Monitoring

Parts on a moving conveyor can be monitored for temperature either continuously – measuring an average of conveyor and part – or discretely – measuring each individual part. For parts which completely or nearly completely, cover the conveyor, measuring continuously will give good results.

A powerful method of improving the optical density of the product as seen by the IRt/c is to angle the IRt/c such that it cannot see between the products. By doing this, temperature monitoring and control can be performed continuously with simple controllers, without the requirement for additional logic.

However, for applications in which each individual part must be measured for communication to a central process control computer, additional devices are

required. The most important are the part detection device, which detects when the part is within the field of view of the IRt/c; and the sample and hold device, which holds the previous reading when the part is not in view. Suitable control modules are available from various manufacturers to provide the necessary logic.

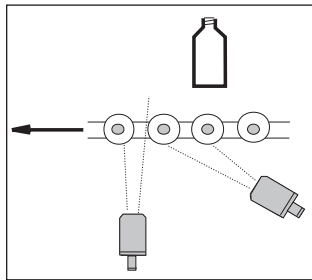

Angling the IRt/c permits it to continuously monitor bottle temperatures

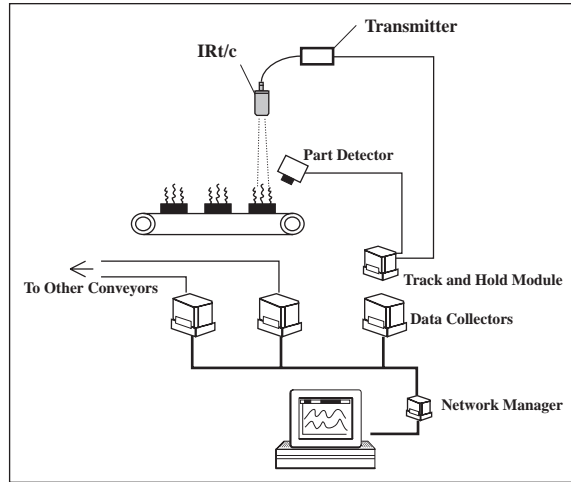

Typical recommended system for discrete part monitoring with IRt/c's.

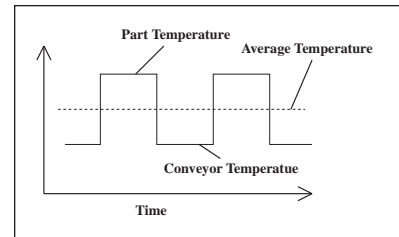

Electric Power Transmission and Distribution Control

The capacity of highly loaded electric power conductors, especially switching and transforming equipment, is limited by the temperature rise characteristics caused by the slight resistive losses. Accordingly, equipment utilization capacity is a direct function of the local temperature at critical points in the equipment.

With continuous real time monitoring with IRt/c's, critical equipment can be used much more effectively. If the temperature is below operating limits, additional power may be safely routed through the equipment. With the non-contact capability of the IRt/c, installation is simple, and live conductors may be safely and easily monitored. Inexpensive standard thermocouple transmitters and data collection equipment may be used to transmit the information to a central office where load switching decisions are made.

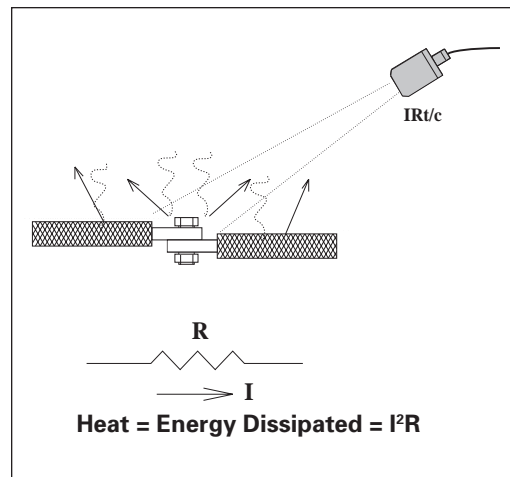

Glass processing, whether of sheets, bottles, or other forms, usually involves temperature as a primary control variable. Since glass is impossible to measure by contact means, plants must use either ambient temperature as an indirect approximation, or an infrared device to measure the glass directly. An often asked question is whether infrared devices can measure glass correctly, since to the eye the glass is transparent.

The answer lies in the physics of glass and the well known "greenhouse effect." The short wave radiation of visible light that we can see (~ 0.3 - 0.8 microns) can pass through glass essentially unaffected. The much longer infrared wavelengths that are normally measured for temperature assessment

(~ 5 - 20 microns) cannot pass through the glass, and are absorbed. As a consequence of the inability of glass to transmit the long wavelengths of infrared, the glass will emit those wavelengths created by its temperature, and thus can be measured with an IRt/c. At much higher temperatures the infrared wavelengths become shorter, and some transmission occurs.

If the glass is within the temperature range of the IRt/c, the sensor will measure its temperature accurately – just as if the IRt/c were looking at an opaque material surface. Follow the normal installation and calibration procedures. The glass will have emissivity in the range of 0.9 and above, and therefore will provide good results.

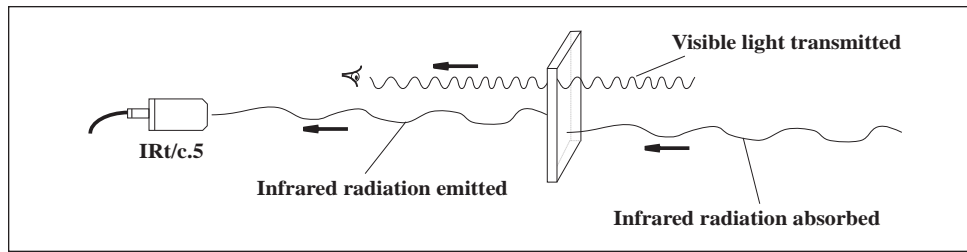

How the IRt/c Temperature Selection Guide Works

All IRt/c's are self-powered devices, which rely on the incoming infrared radiation to produce the signal through thermoelectric effects. Accordingly, the signal will follow the rules of radiation thermal physics, and be subject to the non-linearities inherent in the process.

However, over a range of temperatures, the IRt/c output is sufficiently linear to produce a signal which can be interchanged directly for a conventional t/c signal. For example, specifying a 2% match to t/c

continued...

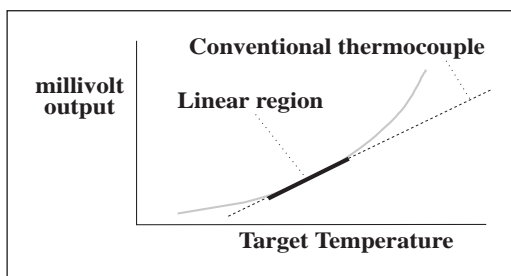

The linear region matches the conventional t/c to a specified tolerance.

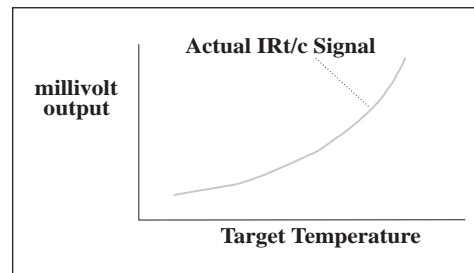

The actual signal generated by the IRt/c can be approximated with a fourth order polynomial function of target temperature. This fourth power dependence is due to radiation physics, and not a limitation of the IRt/c.

linearity results in a temperature range in which the IRt/c will produce a signal within 2% of the conventional t/c operating over that range. Specifying 5% will produce a somewhat wider range, etc.

Each IRt/c model is specifically designed for optimum performance in the region of best linear fit with conventional t/c's, but can be used outside of this range by simply calibrating the readout device appropriately. The output signal is smooth and continuous over its entire rated temperature range, and maintains 0.01°C repeatability over its entire range.

The *Temperature Selection Guide* is a summary of the linear range performance of each IRt/c model.

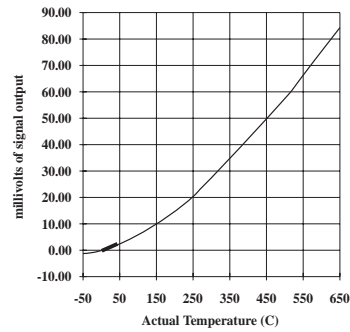

Signal produced by the IRt/c-K-80F/27C has its 2% linear range centered at 80°F (27°C), but produces a repeatable signal to 1200°F (650°C).

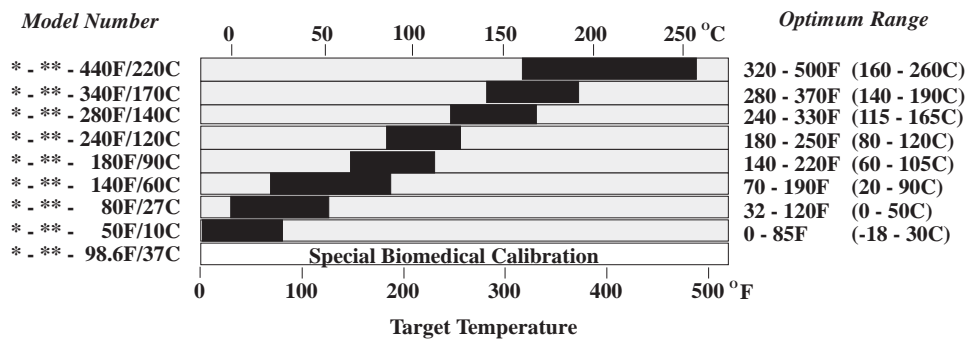

Tech Note

50

Improving Machining Tolerance

Precision machining tolerances of metal and non-metal parts are substantially impaired by uncertainty in part temperature, due to the dimensional changes which occur with temperature. For example, most metals have thermal expansion coefficients of approximately 10 ppm per °F (approximately 20 ppm per °C). If a 10 inch (25 cm) part undergoing machining increases in temperature by only 10 °F (5 °C) from the set-up, the part will have increased in size by .001 inch (.025 mm). Accordingly, the best that the machine can do, **regardless of the machine's quality, is ± 0.0005" (± 0.012 mm).**

If the temperature uncertainty is higher, the tolerance increases in direct proportion. This effect is especially important as the tool wears, and significantly more frictional energy is imparted to the part.

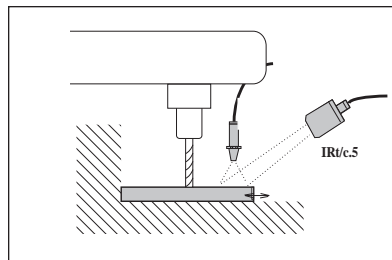

The IRt/c solves the problem by monitoring the part temperature continuously, and reporting the temperature to the computer, which in turn adjusts the position of the cutting tool accordingly. An additional benefit is detection of worn tools, due to the higher than anticipated part temperatures, or rate of change of temperature.

Any of the IRt/c models can be used, although the IRt/c.3x and .5 are preferred for their narrower fields of view and built-in air purge. Emissivity of the metal parts is normally not a problem due to the presence of cutting oils and coatings. If the parts are

completely clean, then a thin coating of oil will be sufficient to increase the emissivity for accurate measurements.

Asphalt Temperature Monitoring

Tech Note

51

Asphalt properties are particularly sensitive to temperature, and it is important that the asphalt is applied at the correct temperature in order to perform to its specifications. Accordingly, temperature monitoring is a common requirement, but the thermocouples normally used have severe breakage problems due to the harsh abrasiveness of the material, and must constantly be replaced at high cost and interruption of production.

The IRt/c solves this problem directly, since the temperature is monitored without contact. The normal thermocouple controller can be used – simply calibrate offset if necessary. The IRt/c.3x and .5 models are recommended for their built-in air purge, which will keep the lens clean by preventing vapors from condensing on the lens. The IRt/c.3x can be mounted in the chute to view the asphalt through a small hole, while the IRt/c.5 can be mounted some distance away due to its narrow 5:1 field of view.

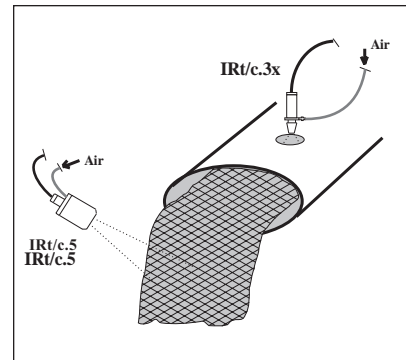

Speed of Response

Tech Note

52

One of the outstanding features of the IRt/c is its speed of response – 0.1 to 0.2 seconds. This attribute makes it possible to monitor the temperature of fast moving materials in production lines, and rapid heating and cooling. For applications in which high speed is required, care should be taken in selection of the readout device, since most thermocouple readouts are much slower than the IRt/c.

In applying the IRt/c, the dynamic characteristics can be described mathematically as a pure exponential response, following the equation:

$$\Delta mV = c(1 - e^{-t/\tau})$$

Accordingly, the IRt/c signal can be modeled analytically for applications in which faster speeds are required. For any given IRt/c, the time constant will be repeatable to within a few percent, and thus can be successfully modelled.

A common limitation in applying the IRt/c to high speed applications is the transit time of the target across the field of view. The characteristic time constant equation of response applies to the IRt/c response only. If the target requires time to completely fill the field of view, the transit time must be

added to the IRt/c time constant. For best results, place the IRt/c as close as possible to the target to minimize the spot size, and therefore the transit time effect.

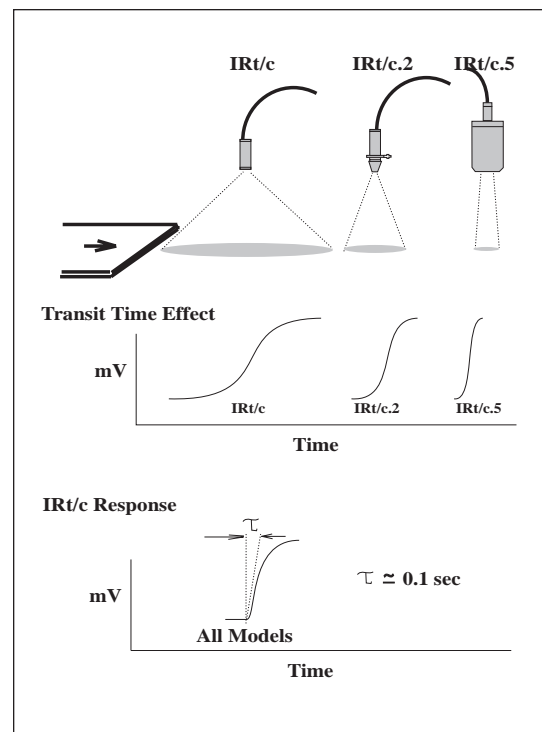

IRt/c Quick Selection Guide

1. How Large Is Your Target?

- If it is smaller than 0.8 inches (2 cm), you must select either the IRt/c.01, IRt/c.03, IRt/c.1x, IRt/c.3x, or focused model.
- If it is smaller than 0.3 inches (8 mm) you must select the IRt/c.3x or focused model.
- If it is larger than 0.8 inches (2 cm), select any of the sensors.

2. How Close Can The Sensor Be Mounted?

- See Tech Note #36, Tech Note #41, and Tech Note #55 and use the field-of-view drawings showing the distance from the sensor versus the approximate diameters of the spot size.
- For example, the IRt/c.3x, at a distance of 3X has a spot size of 1X (at a distance of 1 foot, the spot size is 4 inches, at a distance of 1.5 meter, the spot size is 0.5 meter).
- See Tech Note #29 if you wish to position an IRt/c at an angle other than 90° from your target surface.
- If using a focused model, refer to individual model specifications for optimum distance.

3. What Is The Ambient Temperature Where The Sensor Is To Be Placed?

- If ambient is less than 160°F (70° C) choose any sensor.
- If ambient is less than 212°F (100° C) choose any sensor except IRt/c.01 and IRt/c.03.
- If ambient is greater than 212°F (100° C), see Tech Note #35 for air cooling flow requirements for the IRt/c Cooling Jacket Kit and IRt/c.XXX built-in air purge/cool system.
- If ambient is greater than 500°F (260°C), it is usually best to specify an IRt/c or IRt/c.2 sensor along with the Cooling Jacket Kit and utilize the water cooling feature. (Cooling the smaller sensors with water is less expensive over time, compared to cooling the IRt/c.5 with air.)

4. What Is Your Target Temperature?

- Use Temperature Selection Guide. See Tech Note #49.

5. Choosing A Temperature Controller/Input Device?

- See Tech Note #37 and Tech Note #14 for help in selecting or using available thermocouple input devices.

How to Use Infrared Effectively

As somewhat less commonly understood methods of temperature measurement, infrared methods have their own characteristics which lead to both good applications and difficult applications. The three simplified rules below will help you evaluate the potential use of infrared techniques, and estimate of the degree of difficulty involved. These rules apply to infrared physics in general, and are not a limitation imposed by the design of IRt/c's specifically.

1. Simple Applications

- All non-metallic surfaces
- Food, Paper, Plastics, Coated Metals, Stone, Clay, Glass, Liquids, Textiles, etc.

2. More Difficult Applications*

- Bare Metals**
- Shiny, unpainted, uncoated metal surfaces**

3. "In Between" Applications*

- Dull Metal Surfaces
- Thin "See-through" Plastics

* For temperatures in the correct range, the *Lo E* models provide very good performance if emissivity variations are not too great.

** It is always repeatability that counts, and there are various "tricks" that can be used to improve repeatability in difficult applications, but experimentation is required.

Understanding Field-of-View

Tech Note

55

IRt/c's are rated optically for their field-of-view by the actual dimensional equations describing their construction. However there are, in practice, some secondary effects which can influence performance, including optical scatter, unwanted reflections, atmospheric scatter, and others.

The graph illustrates the relative contribution to the signal produced by the target and by the area surrounding the target due to these effects. Note that the sum of radiation from the target and radiation from the surroundings is always one, and as the sensor is placed further away than its rated field-of-view, there is less target signal and more surroundings signal. Mathematically this effect is identical to a reduction in emissivity, and can be calibrated out the same way, as long as the temperature of the

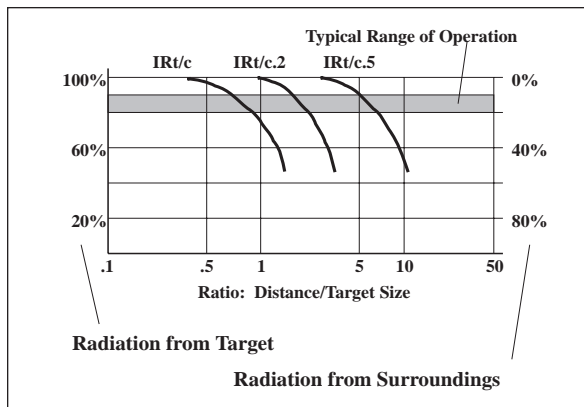

surroundings is repeatable. Under typical conditions, placing the IRt/c such that the target exactly fills the field of view results in approximately 80 to 90% target signal, and 10 to 20% surroundings signal.

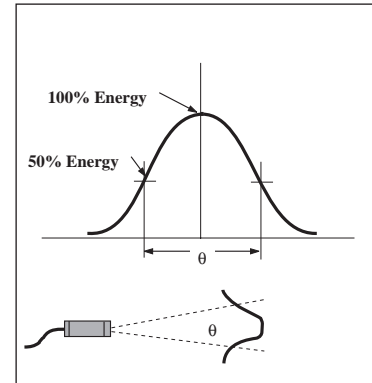

A common convention in infrared thermometry, and the one used to verify the optical performance of IRt/c's, is to define the field-of-view by the "1/2 energy points" in an optical traverse experiment. The resultant data looks like a "Bell Curve" as indicated in the illustration.

The field-of-view is simply the angle between the 50% energy points.

As always, closer is best; use the closest possible position for the IRt/c.

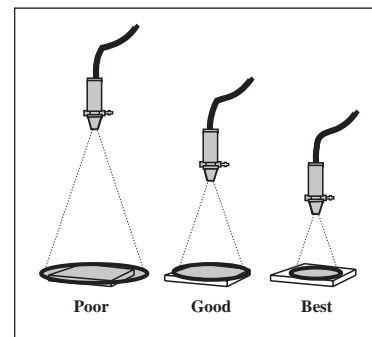

Calibrating with Thermocouple Simulators

Tech Note

56

A common practice in thermocouple transmitter calibration is to set the 4 to 20 mA range on the bench before installation. The usual procedure is to employ a thermocouple simulator which can be programmed to produce a thermocouple equivalent signal of the desired type and temperature range. In this fashion, the 4 mA is set with the ZERO, and the 20 mA with the SPAN for the desired range.

Bench calibration of a transmitter can be performed to operate with any IRt/c by adding the following step to the normal method:

- Measure the electrical resistance of the IRt/c to be used with the transmitter, and add a resistor of the same value in series with the simulator.

With this step, the simulator "looks" to the transmitter exactly the same as the IRt/c, and any offsets caused by transmitter leakage currents can be calibrated out. Good practice is to check to make sure that the calibration remains stable on the bench, in case the transmitter leakage current is not constant. As always with infrared devices, a final trim calibration should be performed in actual operation (see Tech Note #1).

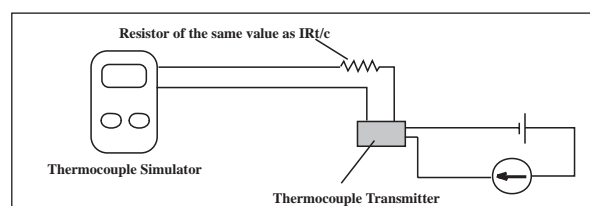

Measuring Objects Smaller Than the Field-of-View

For some non-contact temperature monitoring tasks, the object to be measured is too small to adequately fill the field-of-view of one of the IRt/c models. The monitoring can still be successfully performed if two conditions are met:

- The object size and distance from the IRt/c are constant.
- The area surrounding the object within the field-of-view of the IRt/c has a repeatable temperature.

The signal produced by the IRt/c represents the *average* temperature within its view. Accordingly, the signal can be represented by the equation:

$$T = (T_t A_t / A) + (T_s A_s / A)$$

where T is the output signal, T_t the target object temperature, A_t the target object area, T_s the surroundings temperature, A_s the surroundings area as seen by the IRt/c, and A the total area seen by the IRt/c.

For example, to measure the temperature of a thin rubber strip 0.1" (2.5 mm) wide moving continuously 1" (25 mm) away from an IRt/c, at a temperature expected to be about 200°F (93°C), and a surrounding temperature at 80°F (27°C). At 1" (25 mm) distance, the IRt/c spot size will be approximately 0.5" (13 mm).

Computing the results for the equation gives:

$$T = (200)(.5)(.1) / [\pi(.25)^2] + (80)[\pi(.25)^2 - (.5)(.1)] / [\pi(.25)^2]$$

This result shows that the average signal will be 31°F (17°C) above the surroundings temperature, compared to an actual object temperature of 120°F (67°C) above surroundings, or approximately one-fourth, which is the ratio of object area to surroundings area measured. Therefore, if the surroundings are expected to be repeatable to 1°F (.6°C), the IRt/c signal will be repeatable to 4°F (2°C). For the final display on a controller, or other read-out device, calibrate in standard fashion by using the available offset adjustment. If the object is to be controlled over a wide range of temperatures, calibrating with a span adjustment will yield greater accuracy.

If the target temperature falls within the range of one of the LoE models, the LoE model should be used, even if the target is not metallic. Since a small target results in the same radiation mathematics as low emissivity, a LoE model will reduce errors due to size change and positioning by a factor of approximately 4. See Tech Note 59.

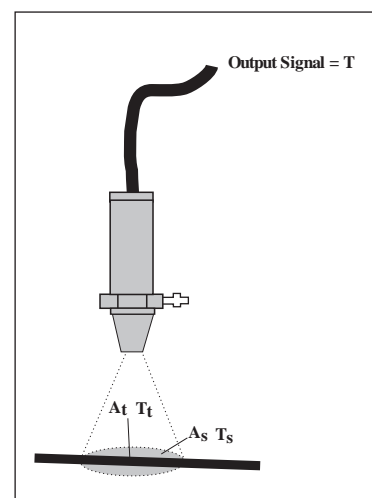
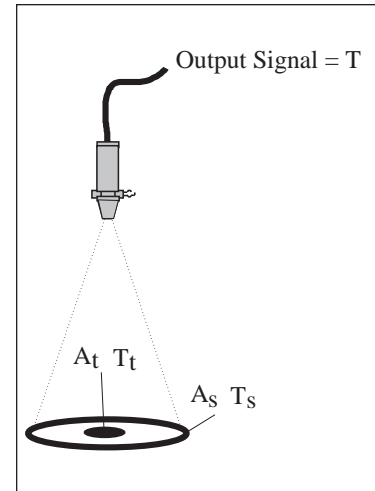

Measuring High Temperatures with Immersion Thermowells

Tech Note

58

Like ordinary thermocouples, the high temperature IRt/c models can be used with immersion “thermowells” to measure high temperature gases or liquids, while maintaining the integrity of the vessel. However, the IRt/c has significant advantages over ordinary thermocouples, RTDs, etc. in this application.

Survivability

Since the IRt/c sensor elements are positioned in a non-contact mode, outside of the heated area, and kept at a low temperature, the entire temperature sensing system can be designed to survive for a much, much longer period of time than conventional thermocouples or RTD’s. The only part requiring maintenance is the thermowell itself, an inexpensive and easily replaced part. Users enjoy savings because there are no replacement thermocouple parts, no replacement labor, and no production losses from downtime for sensor replacement.

Sensor Stability and “Drift”

Even worse than sensor failure is a sensor that reads incorrectly, feeding inconsistent or inaccurate information to your control systems. Sensor stability and drift can be significant problems with standard thermocouples when measuring high temperatures, due to chemical and metallurgical changes that long exposure to high temperatures causes. The IRt/c, however, is essentially immune to those effects, since the sensor remains at a low temperature – far below that of the contact device, and below the levels which are the major sources of drift.

Sensor Speed

With its 0.1 to 0.2 second response time, the IRt/c is far faster than any conventional thermocouple or RTD placed inside a well. Accordingly, for all practical purposes, the temperature measurement speed is the same as that of the well itself.

How To Use The IRt/c With A Thermowell

The technique is to mount an IRt/c sensor so that it aims directly into a hollow thermowell. The well should have a minimum inner diameter to accommodate the minimum spot size of the sensor selected. Choose the appropriate sensor for the temperature range and length of the well you are using.

For example, to measure up to 2000°F (1100°C), 6 feet (2 m) into a stack, use an IRt/c.100A-HiE sensor looking into a thermowell of that length with an inside diameter of at least .8 inches (20 mm). The spot diameter for the IRt/c.100A at 72 inches distance is .8 inches (at 2 meters distance, the spot diameter is 20 mm.) The sensor can then “see” all the way into the hollow well tube and monitor the tip end temperature, ignoring the sidewall temperatures.

Choose appropriate thermowell material (stainless steel, Hastelloy®, Inconel®, ceramic, etc.) to withstand the temperature, oxidation and other rigors of the environment where it is to be placed.

If the thermowell is sealed with a sight glass, then a *Lo E* model should be specified (see Tech Note No. 66).

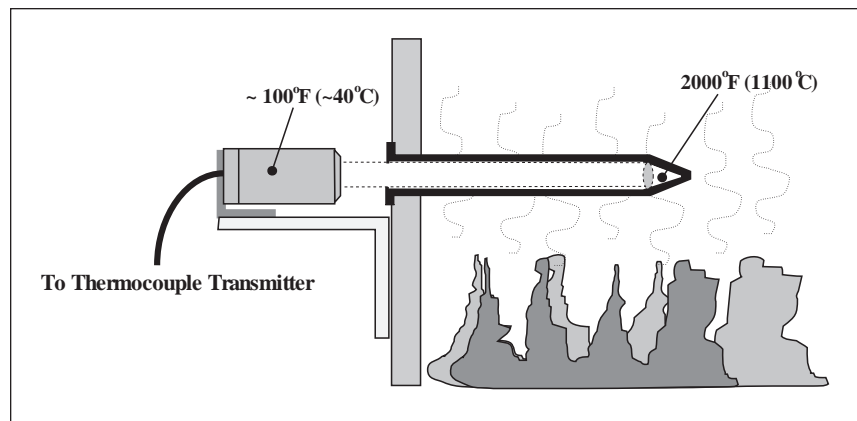

How the Lo E Filter Reduces Errors Due to Emissivity Variations

Emissivity is the property of a material's surface that describes its "efficiency" at emitting thermal radiation. An emissivity value of 1.0 represents emission at 100%, and 0 describes emission at 0% (or perfect reflection - see Tech Note #31).

For non-metals and coated metals this efficiency of emission, called *emissivity*, is very high (0.8 or greater), and variations are usually not a problem. For example, for a production process in which a non-metallic material is to be controlled, and normal material variations cause emissivity variations of ± 0.01 , the associated temperature error will be of the order of .01 divided by .9, or $\sim 1\%$ of reading, an acceptable variation. In contrast, if we are to control the temperature of a metal with emissivity 0.2, then variations of ± 0.01 will produce an error of the order of $(.01/.2)$, or $\sim 5\%$ of reading. Additionally, metal finishes, which play a significant role in emissivity, tend to cause more variations than changes in finish in non-metals.

The IRt/c *Lo E Filter* design filters out the effects of these emissivity variations on measured temperature by approximately a factor of four, and thus reduces the errors by a factor of four. Thus, with the *Lo E Filter*, the errors are of the same order as those commonly experienced for high emissivity targets.

The method takes advantage of the basic physics of thermal radiation, in which the mathematical descrip-

tion of the energy distribution is by a formula called the Planck function:

$$q_\lambda = \epsilon \frac{2\pi hc^2 \lambda^{-5}}{e^{ch/k\lambda T} - 1}$$

where q_λ is radiated energy at a given wavelength, ϵ is the emissivity, T the absolute target temperature, λ the wavelength, and the other symbols are for various physical constants. The Planck function integrates to the more familiar Stefan-Boltzman equation:

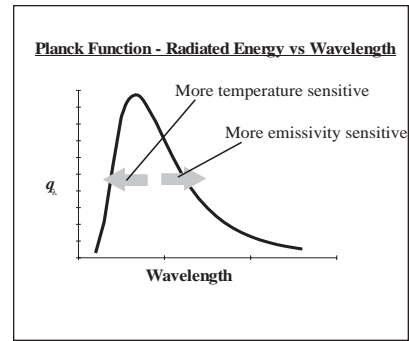

$$\text{Radiated Energy} = q = \int_0^\infty q_\lambda d\lambda = \epsilon \sigma T^4$$

when all wavelengths are measured.

The *Lo E Filter* works by measuring the energy content of the radiation, as described by the Planck function, over wavelengths that are more selectively sensitive for temperature variations, and therefore proportionately less sensitive to emissivity variations, as follows:

$$\text{Filtered Radiated Energy} = \int_{\lambda_1}^{\lambda_2} q_\lambda d\lambda \approx \epsilon \sigma T^x$$

where $x \gg 4$

If we compute the partial derivative of each expression with respect to emissivity and temperature, we obtain the following relations for the slope of the signal with respect to temperature divided by the slope of the signal with respect to emissivity:

$$\frac{\partial}{\partial \epsilon} (\epsilon \sigma T^4) = \sigma T^4, \quad \frac{\partial}{\partial T} (\epsilon \sigma T^4) = 4\epsilon \sigma T^3 \Rightarrow \frac{4\epsilon \sigma T^3}{\sigma T^4} = \frac{4\epsilon}{T}$$

$$\frac{\partial}{\partial \epsilon} (\epsilon \sigma T^x) = \sigma T^x, \quad \frac{\partial}{\partial T} (\epsilon \sigma T^x) = x\epsilon \sigma T^{(x-1)} \Rightarrow \frac{x\epsilon \sigma T^{(x-1)}}{\sigma T^x} = \frac{x\epsilon}{T}$$

where $x \gg 4$

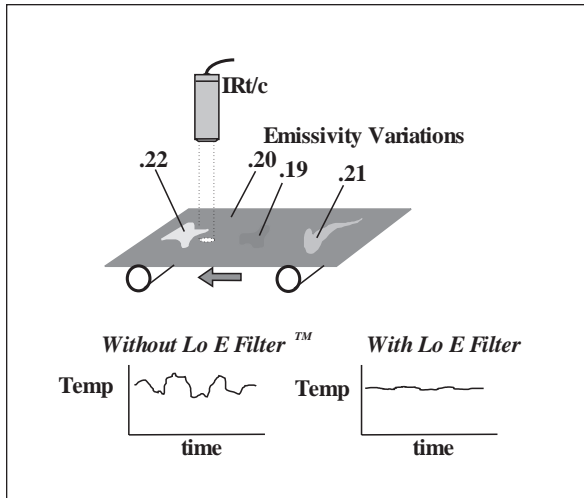

Accordingly, by optimum selection of the wavelengths to be measured, the sensitivity to emissivity variations can be significantly reduced, *i.e. filtered*, by enhancing the relative sensitivity to temperature. In practice, the best wavelengths are the shorter ones, since they provide the most sensitivity to temperature, and the least sensitivity to emissivity, as is predicted by the integration of the Planck function.

The “filtering factor” for the IRt/c Lo E models is based on the selection of .1 to 5 micron for the measured wavelengths, and results in a factor of from four to six error reduction, depending on target temperature.

As an additional benefit of the *Lo E Filter*, errors due to such factors as smoke, dust, moisture, etc. which may partially block the optical path to the target, are also filtered. These factors behave mathematically identically to emissivity, and therefore will be filtered by the same factor of four to six.

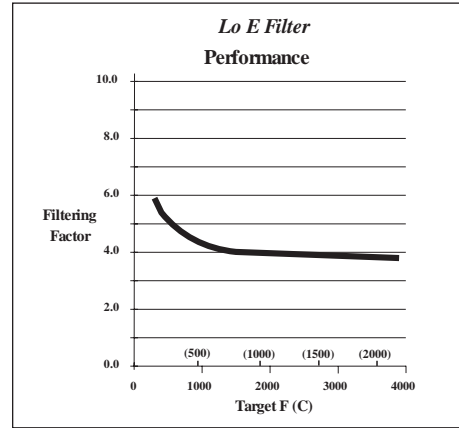

Set-up and Calibration Instructions for Adjustable Models

Tech Note
60

For all IRt/c Models with “A” in model designation (IRt/c.xxxA)

1. Connect air purge first if installing in process already at operating temperature. Provide minimum 5 psig (30 kPa) air pressure.
2. Install IRt/c and align to view the desired target. Bring target to operating temperature if not already there. Connect leads to readout device to be used (controller, PLC, etc.).
3. If the target temperature is not known, measure the target temperature with an accurate reference. Remove the setscrew to expose the calibration screw. Adjust the calibration screw to obtain reading desired. Replace the setscrew cover when complete. For final process adjustments, the ZERO or OFFSET adjustments available on readout devices can be conveniently used.

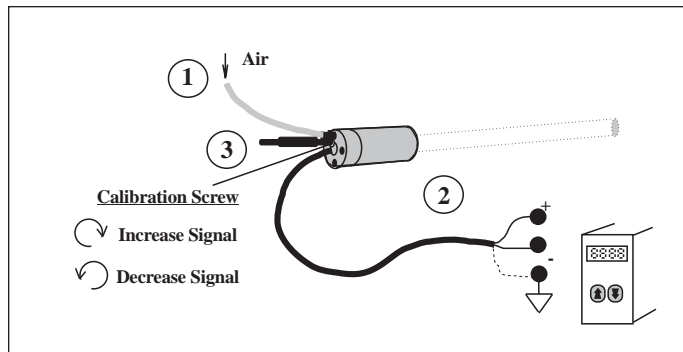

Installation and calibration complete.

To maximize the linear range, see *Tech Note #70*.

Calibration screw operates like a radio volume control: clockwise increases signal.

How the Adjustable IRt/c Models Work

All IRt/c models with the "A" designator (example: IRt/c.10A-K-LoE) can be field calibrated for the specific requirements of the application to precisely indicate the actual temperature of the target, and to correct for reflective errors caused by ambient variations (see Tech Note #64).

The basic operation of the IRt/c adjustment is to rescale the signal output until it matches the actual temperature for the thermocouple type in use. In the vicinity of the calibration point, the output will match the linearity of the t/c. When the adjustment is made to actual temperature, the Automatic Ambient Compensation System is automatically correctly scaled.

The above chart shows the actual performance of a .10A-HiE model as an illustration of the effect of adjustment on the signal.

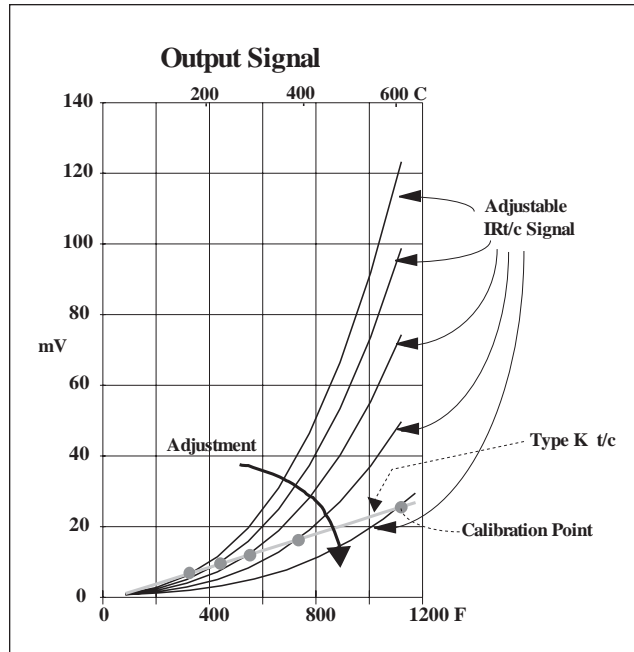

Why Color Does Not Affect Readings

In many IRt/c installations, such as paint curing, web drying, printing, etc., the temperature control system must be able to accurately measure materials with a variety of colors. Ideally the same calibration set-up would be used for all colors, rather than having to recalibrate each time a new color is run.

Because the IRt/c measures the radiated wavelengths that indicate temperature, which are generally ten times longer than the wavelengths that indicate color, color changes do not influence temperature readings. Even for situations in which the target temperature is sufficiently high such that appreciable energy is radiated at visible wavelengths, *all IRt/c models except Lo E completely filter out the visible wavelengths.*

Except to the extent that color might indicate a change in surface texture, and thereby affect emissivity, there will be no effect of color on the reading.

The energy contained in the radiation we see as color has nothing to do with the temperature (except if the target is hot enough to be incandescent), and is simply a function of which particular wavelengths are reflected to our eyes.

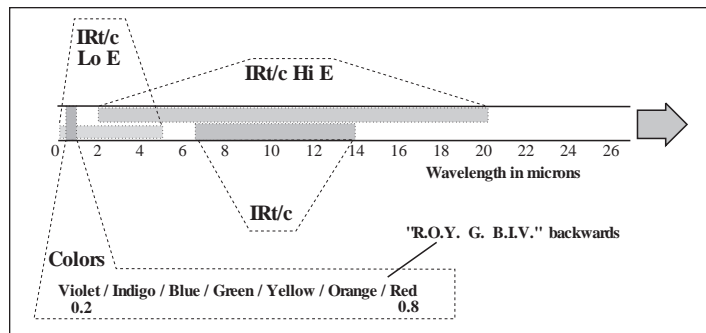

Potential Errors Caused By Ambient Temperature Effects

Tech Note
63

If the ambient temperature of a temperature control installation changes significantly, there are several sources of potential inaccuracies that can be minimized by attention to installation details.

Reflective Errors: For situations in which the IRt/c itself is at the same temperature as ambient sources of radiated energy, the patented design of the IRt/c will compensate for reflected energy and maintain accuracy. See Tech Note #64 for discussion.

If the ambient source of radiant energy is too hot for an uncooled IRt/c, the principal precaution to employ is to take advantage of the generally *specular* characteristics of reflected energy. The term specular means “mirror-like,” and reflective errors can be minimized by avoiding viewing angles in which the surface can reflect a hot source.

Leakage Current Effects: For installations in which the readout device generates appreciable leakage current, there is a potential inaccuracy due to small shifts in IRt/c impedance with ambient temperature. For example, if the readout device leakage current

generates an offset of 100°F (55°C), which is calibrated out at installation, and sometime later the ambient temperature for the IRt/c is much hotter, the IRt/c impedance might be a few percent different than it was at calibration. Accordingly, the temperature offset caused by the leakage current will also shift by a few percent. If the original offset requirement is 100°F (55°C), then a shift of ~ 5% impedance will cause a shift in reading of ~ 5°F (~ 3°C). In general, always choose a readout device with the lowest leakage current available to avoid this potential problem. See Tech Note Nos. 14, 16, 37, and 56 for further discussions of leakage current effects.

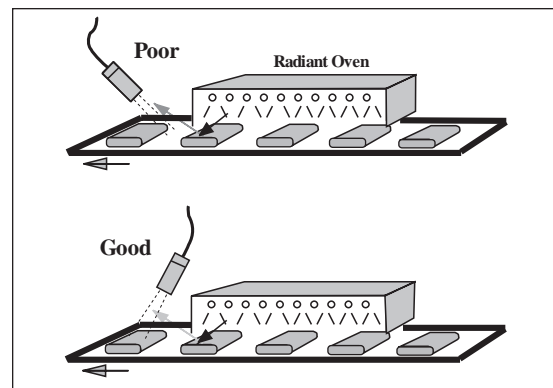

Adjustable Models Compensate for Reflective Errors

Tech Note
64

For high precision temperature control in applications where the ambient temperature varies, reflective effects may cause unacceptable errors under some operating conditions. For example, an incubator is designed to warm a baby by measuring the child's skin temperature, and modulate the ambient temperature inside the incubator to maintain the skin within the desired range. Even though skin has a high emissivity (> 0.9), there is potentially an error of ±1°F (0.6°C) caused by changes in the reflective

component of the radiation as the ambient is modulated ±10°F.

The basic principles can be understood by considering the radiation leaving a surface, as measured by any detector (including an eye). The total radiation q is made up of the reflected and emitted radiation components as follows:

$$q_a = \text{ambient radiation} = \sigma(T_a)^4$$

$$q_r = \text{reflected radiation} = \rho q_a$$

$$q_e = \text{emitted radiation} = \epsilon \sigma(T_s)^4$$

where ρ is reflectivity, ϵ is emissivity, σ is the *Stefan-Boltzman constant*, and T_a and T_s are absolute ambient and surface temperature respectively.

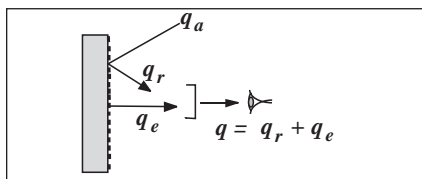

continued...

Since emissivity plus reflectivity is always unity for non-transparent surfaces, the total radiated energy can be written as:

$$q = q_r + q_e = (1-\epsilon)\sigma(T_a)^4 + \epsilon\sigma(T_s)^4$$

This expression can be further simplified into a linear approximation that applies to the ambient temperatures over which the IRt/c can operate uncooled:

$$T = (1-\epsilon)T_a + \epsilon T_s$$

where T is the apparent surface temperature measured by radiation. As indicated by the final result, if the emissivity is 1.0, the effect of ambient temperature is zero. If the emissivity is 0.9, the effect of ambient temperature is 10%, etc. (As an aside, this expression can be used to obtain the actual emissivity.)

Non-adjustable IRt/c's are designed and calibrated to automatically compensate for this effect when the

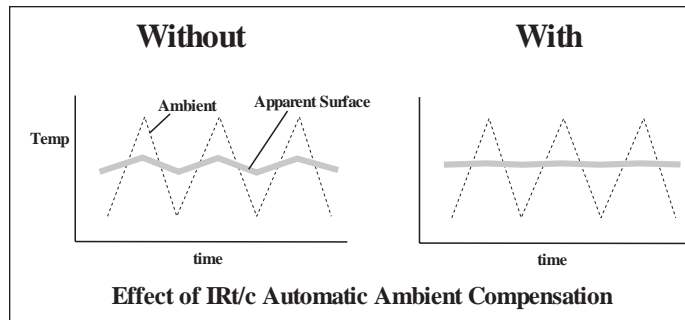

emissivity is 0.9, a good general assumption for most non-metallic materials, and sufficient for good accuracy under most conditions. *With the adjustable models, however, when the IRt/c is calibrated in place it automatically compensates for the reflective errors as indicated in the above equation for any emissivity within its normal operating range.* This patented automatic ambient compensation feature significantly improves the IRt/c control accuracy under real world conditions of varying ambient temperatures.

Tech Note

65

Painting Metal Surfaces to increase Emissivity

Even with the availability of *Lo E Filter* models, as a general rule higher emissivities require less careful attention to set-up details and calibration, and are more "forgiving" in long term service using any IR temperature measuring device. Accordingly it is recommended that where possible, surface emissivity should be increased. If it is not possible to increase emissivity, then a *Lo E Filter* model should be specified.

As an example, to control a metal roller temperature, paint either the end or an unused edge, and monitor with an IRt/c.

A recommended paint for most service is

RUST-OLEUM®

7778

BAR-B-Q-BLACK

Rated to 800°F (427°C)

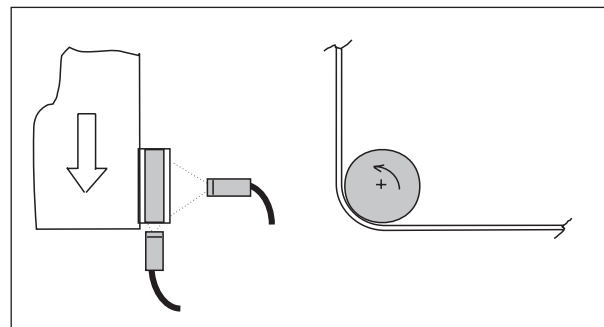

Looking Through Sight Windows with *Lo E* Filter Models

Tech Note
66

Commonly, many types of furnaces are equipped with sight windows to permit visual inspection of the processing of the materials. These windows would conveniently provide a means for monitoring the temperature if the IR sensor could deliver reliable readings through the glass. Such glass can be normal window glass, tempered glass, quartz, etc.

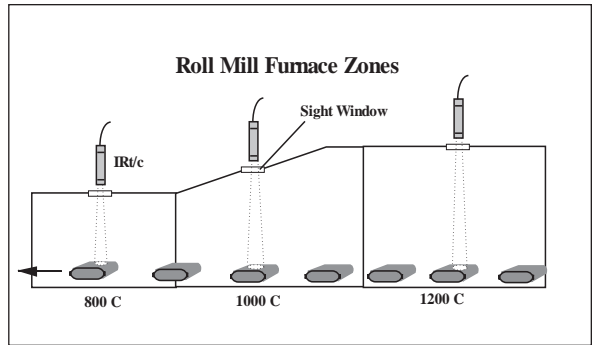

Approximate Signal Loss Through Sight Glass

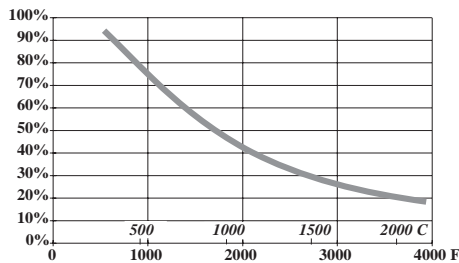

Lo E IRt/c models can “see through” such windows and will provide reliable readings if the losses are not too great. The adjustability feature of these models allow them to be calibrated to include the loss through the window. As a general recommendation, targets above about 500°C should provide good results, but the only way to be sure is to actually install the appropriate IRt/c and monitor results. If there is insufficient signal to read out the correct temperature, the OFFSET adjustment on the readout device may be used to add signal.

Measuring Location of Dry-Out Point in Web Production

Tech Note
67

For many types of continuous web production processing, such as paper, printing, photographic film, textiles, etc., an important parameter for quality and throughput rate is knowledge of the point at which “dry-out” occurs. More important even than the absolute temperature, the location of this point provides a highly precise indication of the rate of heat input into the product, and allows direct control of the energy input to force the dry-out point to a specific spot in the drying process.

The IRt/c is particularly well suited to this application due to its small size, low cost, outstanding speed, hermetically sealed construction, and its intrinsically safe character.

Connected to inexpensive multi-channel thermocouple input cards for PLC’s or computers, the dry-out point is easily calculated by the intersection of the slopes of the temperature vs. position data provided by the IRt/c’s.

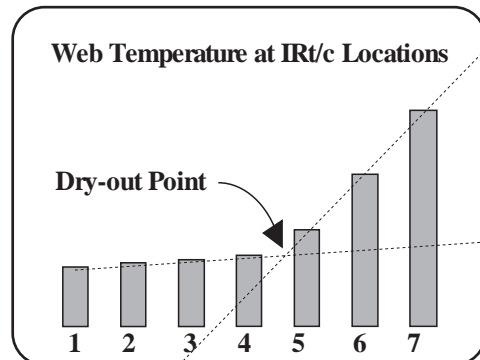
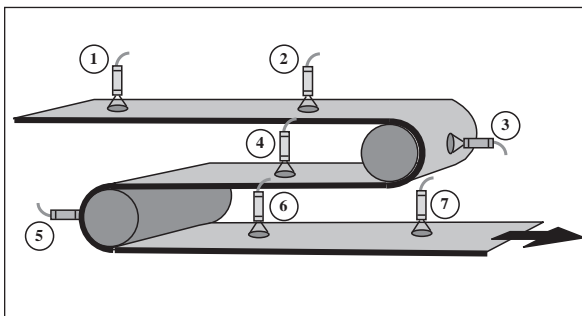

Fail-Safe Control Installation Methods

Although extraordinarily reliable, like any other measuring device, an IRt/c installation should be designed to “fail-safe” under all foreseeable situations. Accordingly, the possible failure modes should be considered as part of the installation design, as recommended in the *Operating Principles* Manual supplied with every IRt/c.

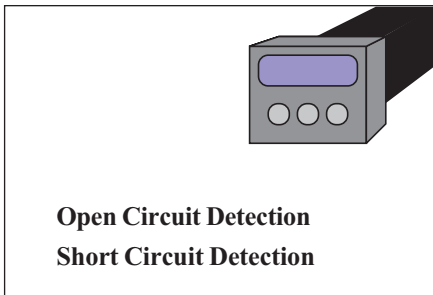

Open Circuit Detection

As in all thermocouple installations, a primary protection recommended is open circuit detection, which will alert if wires are broken, or if the IRt/c is physically damaged to the point of opening the electrical circuit. Standard circuit techniques involve using a small leakage current that generates negligible voltage when the circuit is closed, but drives the input amplifier into saturation if the circuit opens. Only a very small amount of current is required, ~ 1 nanoamp, which produces a negligible signal offset with the higher impedance of the IRt/c, although some devices produce far more current than required, and thus produce more offset (see Tech Notes #16, 37).

Short Circuit Detection

Also a commonly available feature of thermocouple control devices, this safety feature detects if the load is on solidly for a time that is too long for the normal process requirements. This would be the case if a thermocouple were shorted somewhere between the measuring junction and the controller, and thus not reporting the temperature of the process, but the temperature at the short. This safety feature in a

controller is highly recommended, since it not only will protect against short circuits, but also against any other possible failure in the IRt/c which might maintain electrical continuity, but renders it blind to the process.

Calibration Drift

There are no known processes that can cause a significant calibration drift in the IRt/c. Since there are no active electrical components, the signal is generated entirely by thermoelectric effects, and the materials are kept at comfortably low temperatures. A significant feature of the IRt/c design and construction is the presence of a Xenon gas fill in the detection system, which provides an immediate and dramatic change in sensitivity (factor of ~ 3) if mechanical damage occurs sufficient to cause a leak (see Tech Note #38). A common *apparent* source of drift can be a dirty lens, since the optical signal will degrade in direct proportion to the lens area blocked. Employing the built-in air purge feature of most IRt/c's prevents this problem.

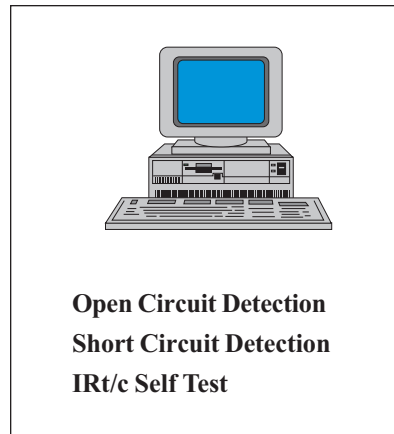

IRt/c Self-Test

A powerful method of checking an IRt/c installation is to test the response against an expected range on *every measurement cycle*. This option is highly recommended if there is computing power available, since it takes full advantage of the fact that any failure of the IRt/c will result in a dramatic change in sensitivity; and thus failure to respond to normal thermal processes will be easy to detect. Refer to Tech Note #39 for further details.

Selecting *Hi E* or *Lo E* Based on Emissivity Table

Tech Note

69

Metals	Emissivity Range	IRt/c Selection
Aluminum		
highly polished plate, pure	0.04 - 0.06	Lo E
oxidized at 1110 F (600 C)	0.11 - 0.19	Lo E
commercial sheet	0.09	Lo E
Brass		
highly polished plate, pure	0.1	Lo E
oxidized at 1110 F (600 C)	0.61 - 0.59	Lo E
Chromium, polished	0.08 - 0.36	Lo E
Copper		
polished	0.05	Lo E
heated at 1110 F (600 C)	0.57	Lo E
Gold, pure, highly polished	0.02 - 0.03	Lo E
Iron and steel (excluding stainless)		
iron, polished	0.14 - 0.38	Lo E
cast iron, polished	0.21	Lo E
cast iron, oxidized at 1100 F (600 C)	0.64 - 0.78	Lo E
wrought iron, polished	0.28	Lo E
wrought iron, dull oxidized	0.94	Hi E
iron plate, rusted	0.69	Lo E
steel, polished	0.07	Lo E
steel, oxidized at 1110 F (600 C)	0.79	Lo E
rolled sheet steel	0.66	Lo E
steel plate, rough	0.94 - 0.97	Hi E
Lead, gray oxidized	0.28	Lo E
Mercury	0.09 - 0.12	Lo E
Molybdenum filament	0.10 - 0.20	Lo E
Nickel		
polished	0.07	Lo E
plate, oxidized at 1110 F (600 F)	0.37 - 0.48	Lo E
Platinum		
polished plate, pure	0.05 - 0.10	Lo E
wire	0.07 - 0.18	Lo E
Silver, pure, polished	0.02 - 0.03	Lo E
Stainless steel		
polished	0.07	Lo E
type 310, oxidized from furnace service	0.90 - 0.97	Hi E
Tin, bright	0.06	Lo E
Tungsten filament, aged	0.03 - 0.35	Lo E
Zinc		
commercial pure, polished	0.05	Lo E
galvanized sheet	0.21	Lo E

Nonmetals	Emissivity Range	IRt/c Selection
Asbestos	0.93 - 0.94	Hi E
Brick		
red, rough	0.93	Hi E
fire clay	0.75	Hi E
Carbon		
filament	0.53	Hi E
lampblack, rough deposit	0.78 - 0.84	Hi E
Glass (Pyrex, lead, soda)	0.85 - 0.95	Hi E
Marble, light gray, polished	0.93	Hi E
Paints, lacquers, and varnishes		
white enamel	0.91	Hi E
flat black lacquer	0.96 - 0.98	Hi E
aluminum paints	0.27 - 0.67	Lo E
oil paints, 16 colors	0.92 - 0.96	Hi E
Porcelain, glazed	0.92	Hi E
Quartz, opaque	0.68 - 0.92	Hi E
Water	0.95 - 0.96	Hi E
Wood, oak, planed	0.90	Hi E

Note: Lower emissivity surfaces require more stable conditions than high emissivity surfaces for accurate temperature control. These tables include approximate values, which can vary significantly with surface condition. For best results, install an IRt/c and test. Emissivity data from *Heat, Mass, and Momentum Transfer* by Rohsenow and Choi (Prentice-Hall, 1961).

Calibrating for Wide Linear Range with Adjustable Models to Standard Thermocouple Inputs

All IRt/c models with the "A" designator (example: IRt/c.10A-K-Lo E) are equipped with a calibration adjustment feature that makes it possible to precisely calibrate the IRt/c to the temperature control requirements. However, for installations in which *monitoring* of temperature rather than *control* is desired, a wide linear range is convenient. Accordingly, the procedure described below can be used to produce a very wide linear range when using controllers, meters, PLCs, transmitters, etc. for temperature monitoring. The only requirement is that an OFFSET, ZERO, LO CAL, or equivalent adjustment be available to offset the reading.

The method involves simply "rotating" the output curve of the IRt/c to better fit the linear thermocouple requirement over a wider temperature range, as shown in the graph. The steps are as follows:

1. Set the readout device to the offset value shown in Table I.
2. Adjust the calibration screw on the IRt/c to the correct target temperature.
3. Calibration complete.

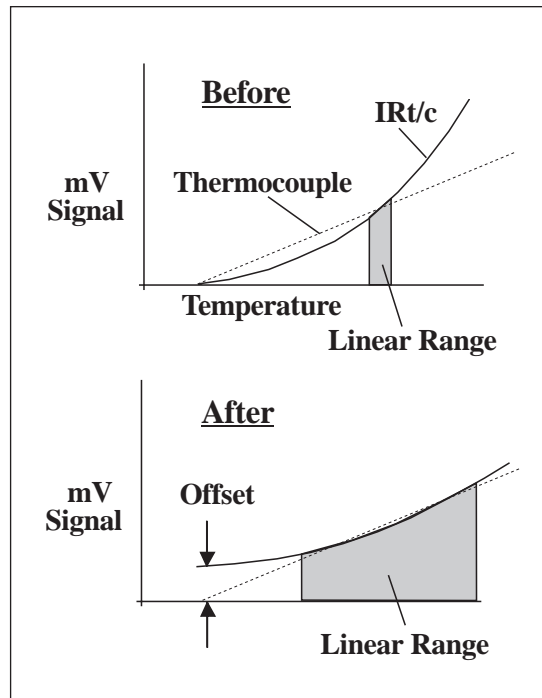

Models: IRt/c.xxxA (Applies to all Adjustable Models)	Target Temperature °F (°C)	Optimum Offset (% of Target Temperature)	Approximate 2% Linear Range (from Target Temperature), °F (°C)
Lo E	800 (425)	~ 75%	± 100 (60)
	1000 (540)	~ 75%	± 150 (80)
	1600 (870)	~ 75%	± 200 (110)
	2000 (1100)	~ 75%	± 300 (170)
	2800 (1540)	~ 75%	± 400 (220)
	3600 (2000)	~ 75%	± 400 (220)
Hi E	200 (90)	~ 60%	± 25 (15)
	500 (260)	~ 60%	± 50 (30)
	1000 (540)	~ 60%	± 200 (110)
	1500 (820)	~ 60%	± 500 (280)
	2100 (1150)	~ 60%	± 600 (330)
	3000 (1650)	~ 50%	± 800 (440)

Example: Apply a Lo E model to monitor steel at 1800°F (980°C). Cover the IRt/c with aluminum foil such that it cannot see the target, then set the readout device offset so that the display reads approximately 75% of target temperature: $.75 \times 1800 = 1350^\circ\text{F}$ ($.75 \times 980 = 735^\circ\text{C}$). Remove foil, point IRt/c at intended target, and adjust the calibration screw on the back of the IRt/c until the readout display reads the correct temperature, or within a few percent of the correct temperature. Fine tune the reading at the readout device as required. The calibration is complete, and the linear range over which the reading will be within 2% of actual is approximately 1800°F ±250°F (980°C ±140°C).

IRt/c infrared thermocouples are revolutionizing the printing industry because their small size allows them to be mounted in the tight spaces typical of both web and sheet fed presses, and their low cost allows economical installation and control on even the smallest of presses. Additionally, since many presses are already equipped with thermocouple controllers and PLC thermocouple inputs, the IRt/c is a simple installation.

Applications include not only printing onto paper, but also cloth, plastic, and any other printing web application.

Location 1: INK ROLLERS, PLATENS

CONVENTIONAL PRESSES (water/ink)

On conventional presses (water/ink processes), the quality of the process is very dependent on the difference in surface tension between water and ink, and this surface tension is highly temperature sensitive. When presses operate, heat is generated due to friction in the pressing area. Heat build-up can significantly alter the surface tension of the water/ink resulting in a deterioration in print quality.

IRt/c sensors easily monitor any roll surface temperatures within presses. Connected to a display with alarm signal, they can alert the operator of deteriorating temperature conditions before poor quality impressions are made. Connected to a temperature controller, PLC or computer, the IRt/c quickly signals an installed press temperature control system to provide cooling to the press area, or signal cooling systems to provide cooling to the ink and/or water supplies to maintain proper surface tension.

Temperature is also important when there is risk of thin wall cylindrical platen(s) becoming loose or sloppy due to thermal expansion (or contraction). On large diameter metal cylinders, a small temperature change can result in a significant change in the circumference of the roll, and thus affect the proper "fit." By measuring

the surface temperature of the roll, the proper fit of the plate can be maintained by either (1) cooling the area or (2) slowing down the press so friction heat decreases to a low enough level to maintain print quality.

WATERLESS INK PRESSES and CONVERSIONS

"Waterless" ink technology involves the use of special inks to eliminate the need for the water/ink combination. This technology has significant cost and performance advantages for the printer in elimination of waste treatment, and higher quality product. The waterless ink technology can be applied to virtually all types (web and sheet fed) and sizes of presses from large multi-color presses down to the small presses.

Conventional presses can be converted to use these inks by providing a method to control the surface temperature of the rolls where the ink is applied to the platens. This is typically done by using hollow rolls and supplying chilled water through the rolls to keep the surface at a desired temperature. The IRt/c is a key component of the package required to convert a press, since waterless inks are very temperature sensitive and must be applied with strict ink and surface temperature control.

The surface temperatures are easily monitored by an IRt/c. The output signal is sent to a discrete temperature controller, PLC, or custom computer control system to regulate the refrigerated circulators providing cooling water.

The IRt/c sensing system is precise enough to also allow manipulation of color characteristics for waterless printing. For example, running a particular waterless ink at different temperature extremes allows for choosing between brilliant or softer colors.

Press locations for IRt/c: 1) Ink Rollers, Platens; 2) Drying/Curing; 3) Chill Rollers; 4) Bindery.

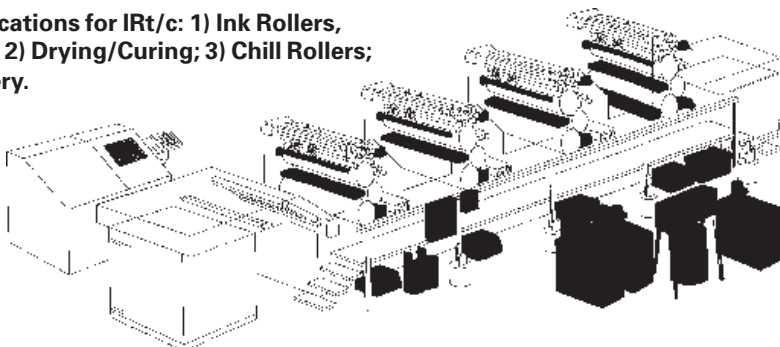

Location 2: DRYING/CURING

After ink is applied to the paper (or cloth, plastic, etc.) in the printing area, the web (or sheet) typically travels through a drying/curing process. IRt/c sensors are used where they (1) "look" directly at the web or sheet while it is inside the dryer or (2) at the web just as it exits the dryer. Either method can be used to control drying temperature or UV curing.

For web presses, a much more accurate way is also possible. By using multiple IRt/c sensors along the web while in the dryer, the actual "Dry-Out" point can be located and controlled within the dryer. See Tech Note #67.

Location 3: CHILL ROLLERS

For web offset printing, as the web leaves the dryer, it runs through a chill roller(s) to cool the web so that the paper (cloth, plastic, etc.) can be cut and stacked, or rolled, without the material sticking together.

By using IRt/c sensors to measure the surface temperature of the web at the point where it is being chilled, the IRt/c signal can control the amount of

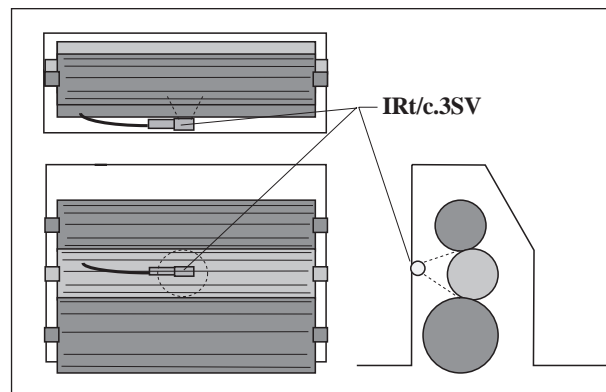
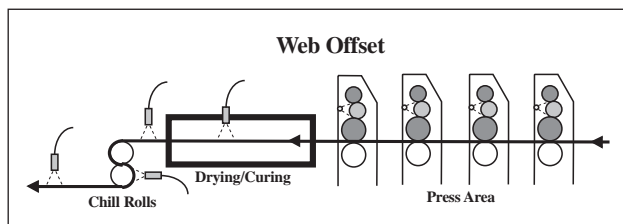

Small size fits into tight press area. The model IRt/c.3SV is recommended due to its convenient side view and extraordinary ability to keep itself clean in the harshest ink spray environments.

chilling. This control will eliminate "over chilling" (condensation problems due to high ambient humidity common in press rooms) and "underchilling" problems, automatically.

Location 4: BINDERY

Hot melt glue guns and applicators periodically "plug up" or run out of glue. Properly used IRt/c sensors or an Exergen AAM system can instantly alert machine operators prior to products being glued improperly. See Tech Note #18 and/or the section on the Exergen AAM Series (Applied Adhesive Monitors) in *The IRt/c Book*.

Tech Note

72

OEM Low Cost Interface

Designing the advantages of infrared temperature sensing into your OEM equipment is now easier and much, much lower cost than it has ever been. The IRt/c product line can be conveniently interfaced with many standard thermocouple devices at the component level for custom board design. For example, Analog Devices, Inc. manufactures numerous low-cost thermocouple input components that work well with the IRt/c, such as the following two models.



Model AD1B60 Intelligent Digitizing Signal Conditioner for the IRt/c

- Complete IRt/c sensor-to-digital signal conditioning and data conversion
- Directly connect up to 4 IRt/c's per chip
- Cold junction compensation built in

- Software switchable open thermocouple detection
- Allows IRt/c linearization over complete temperature sensing range
- Digital output
- Under \$50 in 100 piece quantities

Model AD594 (type J), AD595 (type K) IRt/c Amplifier with CJC

- Direct connection with IRt/c sensors
- Built-in cold junction compensation
- 10 mV/deg C output (0 to 10 V output)
- Under \$7 per unit in 100 piece quantities (AD594AQ)

For more information about component level IRt/c design, or assistance in board level design for interface with the IRt/c product line, please contact Exergen directly.

Contact Analog Devices directly for information on these and other models: Analog Devices, Inc., One Technology Way, PO Box 9106, Norwood, MA 02062 (Phone: 800-262-5643, 617-329-4700)

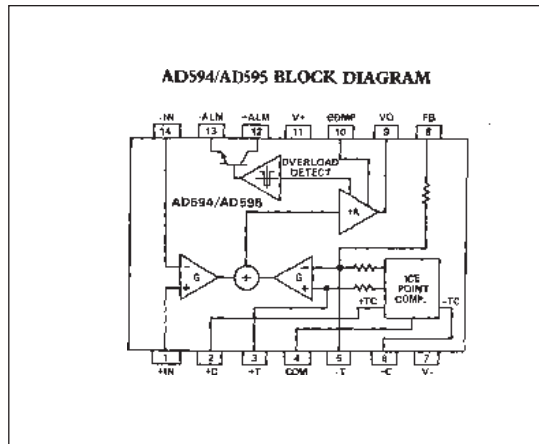

Flame Detection

Tech Note
73

Many industrial processes involve highly flammable materials and are a constant potential hazard. As a result, for safety and loss prevention, flame detection devices are specified to alert or shut down the process in the event of a fire. The IRt/c, alone or in conjunction with other devices can provide a good solution. *Since the IRt/c is intrinsically safe, it can be mounted in the hazardous area when used with the appropriate barrier (see Tech Note No. 10), thus making it suitable for locations not possible with other flame detection devices.*

The recommended model is the IRt/c.10A-K-LoE. With spectral sensitivity of 0.1 to 5m, this model will measure the short wave radiation created by a flame, while filtering out the changes in ambient target temperature.

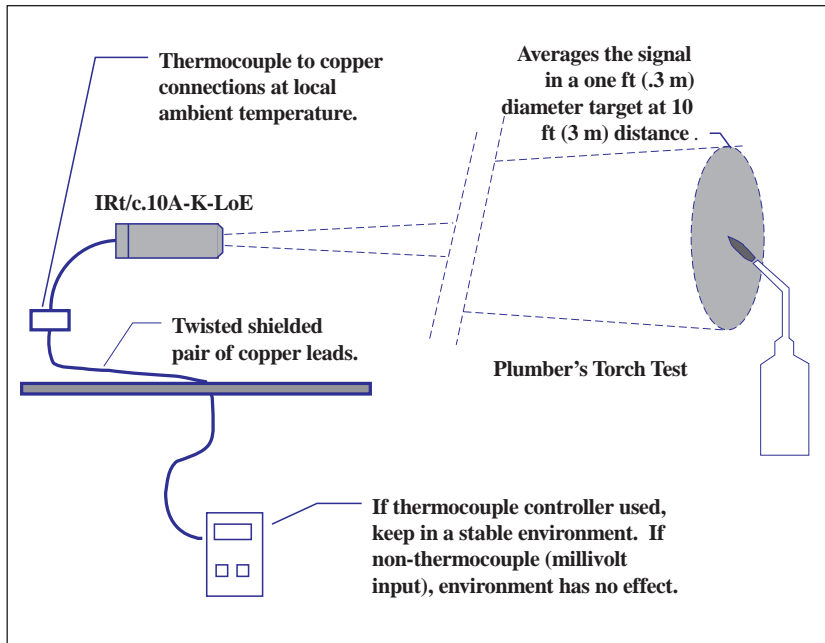

It is strongly recommended that the system be tested for the desired response and control set-up. For example, the ability of the system to detect a plumber's propane torch flame at 10 ft (3 m) can be tested, resulting in an indicated temperature rise of the order of 50°F (30°C). The monitor/controller can be set appropriately, and all flames that are larger or more luminous than the torch will alarm. Customary testing, redundancy, etc. should be observed, as required for the application.

Calibration Testing Procedures

For many OEM and general temperature control applications it is sometimes desirable to test sensors before being placed into service, or to conduct routine checking while they are in service. Accordingly, recommended procedures are presented to allow easy checking with commonly available equipment. However, prior to testing, it is important to understand what indications an actual IRt/c failure might cause.

Factory Calibration

The pre-calibrated IRt/c sensors (models without the "A" suffix that indicates user adjustability) are calibrated under conditions that optimize performance in actual use: target emissivity = 0.9 (a good general value for non-metals), and ambient temperature elevated to approximately 1/4 of the elevation of target temperature above room temperature (accurately simulates the effect of reflected energy). Since this type of test would require specialized devices, the procedures outlined have test standards that are slightly different, since they use blackbodies, or test surfaces/ambients whose properties vary to some extent.

What to Look For When Testing

Open Circuit: An open circuit (resistance > 15 K Ω) indicates a broken wire, and open circuit detection systems will perform normally to detect it.

No Response to Thermal Radiation: Sensor reads ambient temperature accurately, but does not respond when pointed at a hot target. This fault is similar to a short circuit with an ordinary thermocouple, in that the circuit is complete, but is measuring the ambient temperature at the short, and not at the measuring junction. For the IRt/c, this fault is the same as if the sensor were covered with foil, thus blinding it.

Sensor Reads Low: There are only two ways an IRt/c can shift after factory calibration: the lens becomes dirty; or the sensor loses its hermetically sealed Xenon gas.

- If the lens becomes dirty, the signal loss is directly proportional to the amount of dirt on the lens. Infrared energy is a form of light and therefore the situation is similar to ordinary window glass becoming dirty and blocking out sunshine. If considerably dirty before cleaning, the window will let more light through after cleaning, thus increas-

ing the signal. If it was already clean, additional cleaning doesn't let any more light through, and the signal remains the same.

- If the durable IRt/c hermetic seal somehow fails, the Xenon gas will immediately escape. For even a small leak, the Xenon will escape quickly, within seconds. It is a "fail-safe" design. The Xenon gas will not leak gradually. If this occurs, the mV output sensitivity will immediately drop to approximately 50% or less of normal signal. For example, if a type K-180F/90C sensor looks at a high emissivity 212°F (100°C) surface and reads correctly on a thermocouple meter, or gives you 3.3 mV on a DVM, then the sensor is within specifications. If the signal is only approximately 1.7 mV, or reads in the neighborhood of 140°F (60°C) with a thermocouple meter (and the lens is clean), the fail-safe gas seal has been compromised.

The fail-safe feature is quite important, since a breach of the sensor gas seal would permit contaminants to enter the sensitive detection system and cause unpredictable drift.

Conducting Pass/Fail Testing

For your convenience, 212°F (100°C) is recommended as a test target temperature, even though it might be outside the 2% linear range of the IRt/c being tested, since the strict repeatability of the IRt/c permits it to be tested at any temperature within its specified range. A digital volt meter (DVM) with at least 0.1 mV resolution is recommended instead of a thermocouple readout, since the DVM will be faster, and will not generate a leakage current that can cause readings to vary from sensor to sensor due to resistance variations. An electronic ice point reference is desirable, but not necessary for pass/fail testing.

Equipment

Best: Accurate Blackbody at 212°F (100°C).

Good Alternative: Pot of boiling water.

Procedure

Make sure the sensor window is clean. If it is not, then clean with a mild solvent such as alcohol and wipe dry. Clip the DVM test leads to the IRt/c and point at the target, bringing the IRt/c as close as possible to be sure that the IRt/c sees only the target, taking care that the clip lead connections (the effective cold junctions) remain at room tempera-

ture. Immediately read the DVM for the correct reading. For details of test set-up for the boiling water, see *Tech Note No. 75*.

In-Service Inspection Methods

Measure the surface temperature of the target (with the target at normal operating temperature) with a Microscanner D-Series infrared thermometer. Make note of the temperature. Check the IRt/c display device and make sure the reading reproduces the original value that was obtained at installation calibration. If the IRt/c reading is incorrect, clean the

lens with a cotton swab and alcohol (or similar cleaner) and recheck the display. If the reading is significantly lower, the fail-safe Xenon charge has escaped, indicating that the sensor should be replaced.

Calibration Values

For specifications for the mV signals that should be obtained for the test conditions obtained above, for any given model IRt/c, please fill in the data below, and fax to Exergen. The specifications will be return faxed to you.

Name _____
Company _____
Phone _____ Fax _____
IRt/c Model _____
Target Material and Temperature _____

Checking Calibration of IRt/c or D-Series with Boiling Water

Tech Note

75

Exergen's Microscanner D-Series are designed as highly accurate and reliable temperature references as well as fast easy-to-use infrared scanners. Since all components making up a D-Series are drift-free *there is never a requirement to calibrate the instrument once it leaves the factory*, and no calibration means is provided on the instrument (except certain high temperature models). Accordingly, if the D-Series calibration has shifted from its factory setting, it requires repair since a component has failed. Similarly, non-adjustable IRt/c models are factory calibrated for life, and if they do not reproduce their calibration, they should be considered failed.

Unless you have technical experience with and have a laboratory infrared "blackbody," this calibration checking technique is recommended by the

factory. Boiling water is a physical constant, easily used, and requires no technical set-up of elaborate equipment or checking of traceable standards.

Boiling Point of Water

The open boiling point of (reasonably pure) water is affected by only one factor: barometric pressure. The standard 212°F (100°C) boiling point is for a barometric pressure of 30.00 inches of Hg (mercury), or in metric terms, 1 Bar (1000 millibars). This is "normal" at sea level. Barometric pressure can be affected by elevation above sea level, and by weather conditions.

Elevation Correction: The boiling point of water is lowered by approximately 2°F (1°C) for every 1000 ft (300 m) above sea level with no unusual weather

continued...



Elevation	Boiling Temperature	
	212°F	100°C
Sea level	212°F	100°C
1000 ft (300 meters)	210	99
2000 ft (600m)	208	98
3000 ft (900 m)	206	97
4000 ft (1200 m)	204	96
5000 ft (1500 m)	202	95

conditions. If your weather is “normal” and you are not using the barometric pressure method, you can simply use the following corrections.

Weather Conditions: If you use this method, you do not need to put in a correction for elevation above sea level. It will be automatic by using the current barometric pressure dominating your area. Barometric pressure can be much lower during especially stormy conditions (low pressure areas), and much higher during extremely cool and dry conditions (high pressure areas). Consult the weather reports on TV, in your local newspaper, or call a weather service office for current barometric conditions in your area. Barometric pressure correction factors:

- 2°F / inch Hg (1°C / 30 millibars) change from 30.00 in. Hg (1 Bar)
- Add to the boiling temperature for higher than normal pressure.
- Subtract for lower than normal pressures.

Note: Always clean the sensor lens prior to calibration testing. A cotton swab with a mild cleaner such as alcohol works well.

Checking Calibration

Required Equipment:

- Metal pot with cover, minimum 4" (10 cm) tall.
 - Solid paint marker or thin opaque tape.
1. Use a metal pot, with cover, for boiling water.
 2. Fill the pot at least 1/2 fill with water.
 3. Use the solid paint marker supplied with your D-Series, or a piece of opaque (non-see through) tape, or a thin electrical tape, to put a measuring spot at least 1 in. (25 mm) in diameter on the outside surface of the pot. Make sure the measuring spot is at, or slightly below, the water level.

4. Bring the water to a RAPID boil. Tilt the cover SLIGHTLY so that the water does not boil over. The condensing steam on the inside of the pot along with the rapidly boiling water will force the outside surfaces of the pot to be within a fraction of a degree of the temperature of the boiling water. (The temperature drop through the wall thickness of the average pot for boiling water is very small and can be ignored.)
5. Briefly touch the nosepiece flat onto the black mark and note the temperature reading. For an IRt/c, bring the sensor as close as possible without touching.

The reading should be within $\pm 2\%$ of the actual boiling point (for example $\pm 2^\circ\text{C}$ for 100°C boiling point). If the reading is not within these limits, the instrument has a failed component and should be returned to Exergen for repair. Please call for an RMA number prior to shipment. For the IRt/c refer to *Tech Note No. 73* for specifications.

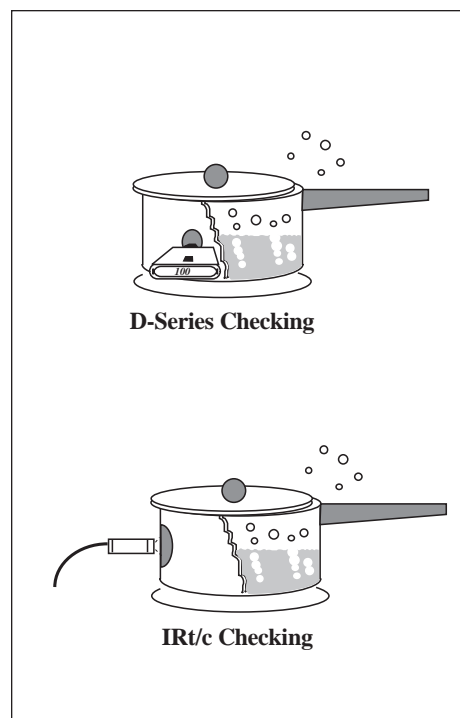

Increasing Temperature Range, Improving Adjustment Sensitivity, and Reducing the Minimum Spot Size with the Aperture Kit

For all IRt/c adjustable models an Aperture Kit is provided to offer the ability to extend the target temperature range, improve the adjustment sensitivity of the adjustment potentiometer, and reduce the minimum spot size to as small as 1/4 in. (6 mm).

The kit consists of one 1/2 in. (13 mm) and one 1/4 in. (6 mm) stainless steel apertures and two retaining rings. The apertures and retainers are installed as shown, taking care that the retainers sit and lock between the internal threads. The precise axial location is not critical. Install only one aperture, based on the requirements of your application.

The function of the aperture is to reduce the quantity of radiated energy entering the IRt/c optical system, thus increasing the rated maximum target temperature before burn-out. In addition, since less signal is produced at a given temperature, the adjustment will be less “tweaky” when calibrating the IRt/c installation. The table below lists the range of temperatures for each model recommended with and without the apertures. These recommendations are approximate, since the actual signal level will depend on the actual target characteristics (emissivity, etc.). If there is insufficient adjustment range available with the small aperture installed, simply replace it with the large one, or remove it. If the adjustment is too sensitive, install an aperture. Use the table below to set up your installation initially, to make sure that the IRt/c is not damaged by excessive radiation, then adjust up or down as required to meet your calibration requirements. The ranges below assume that you are using the technique described in Tech Note #70 or an equivalent calibration method.

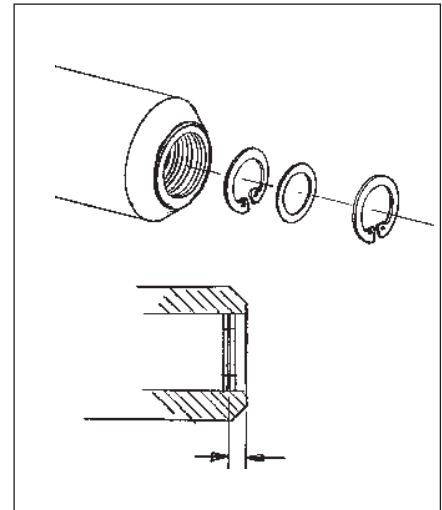

Model	No Aperture	1/2" (13mm) Aperture	1/4" (6mm) Aperture
IRt/c.10A- ** - HiE IRt/c.xxxACF- ** - HiE IRt/c.xxxAMF - ** -HiE	to 700°F to 370°C	500 to 1500°F 260 to 820°C	1300 to 2500°F 700 to 1370°C
IRt/c.10A- ** - LoE IRt/c.xxxACF- ** - LoE IRt/c.xxxAMF - ** -LoE	to 1400°F to 760°C	1200 to 1800°F 650 to 980°C	1600 to 2500°F 870 to 1370°C
IRt/c.20A- ** - HiE IRt/c.xxxALF - ** -HiE	to 1200°F to 650°C	1000 to 2500°F 540 to 1370°C	2300 to 3000°F 1260 to 1650°C
IRt/c.20A- ** -LoE IRt/c.xxxALF - ** -LoE	to 1800°F to 980°C	1000 to 2500°F 540 to 1100°C	2500 to 3500°F 1370 to 1930°C
IRt/c.100A- RS -HiE IRt/c.xxxAXLF - RS -HiE	to 2500°F to 1370°C	2000 to 4000°F 1100 to 2200°C	3500 to 5000°F 1930 to 2760°C
IRt/c.100A- RS -LoE IRt/c.xxxAXLF - RS -LoE	to 3500°F to 1930°C	2500 to 4500°F 1930 to 2500°C	4000 to 5000°F 2200 to 2760°C

IRt/c Tested at 5000 psig (340 bar) Pressure

For some types of processes, it is necessary to monitor temperatures of materials subjected to high gas pressures. Conventional contact devices are difficult to employ under these conditions and conventional IR devices are unsuitable because their optical and electronic components are unable to withstand high pressures.

With its elegant simplicity and solid construction, the IRt/c provides a solution. It has been tested at pressures up to 5000 psig (340 bar). A simple ferrule type tubing fitting may be used to provide a pressure-tight seal around the IRt/c housing. If using an IRt/c model with a lensed optical system (IRt/c.5; IRt/c.10; etc.), pierce the lens at its edge with a needle to provide pressure equalization.

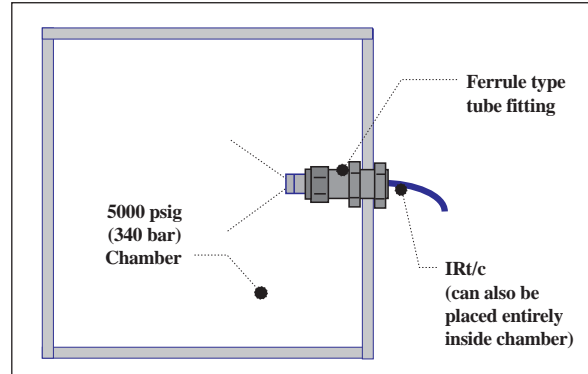

IRt/c Tested for Vacuum and Microwave Compatibility

Tests for compatibility performed by customers contribute greatly to our understanding of how IRt/c's perform in some of the unusual environments where non-contact temperature measurements are required. Exergen has a policy of providing sensors free of charge to any laboratory for test purposes, in return for a copy of test results. This series of tests was performed by a customer who required the performance, and had the facility to test the IRt/c. The test was conducted in a 4 ft. by 4 ft. (1.2 m by 1.2 m) chamber in the following sequence:

First Test

1. Vacuum exposure (15 minutes at 40 Torr)
2. Microwave Exposure (5 minutes, 3 KW at 2450 MHz)
3. Chamber load (15 pounds H₂O)

Second Test

1. Vacuum exposure (10 minutes)
2. Microwave Exposure (30 seconds, 3 KW at 2450 MHz)
3. Microwave Exposure (10 seconds, 3 KW at 2450 MHz)
4. Chamber load (1 pint H₂O)

The IRt/c showed no ill effects and operated flawlessly when checked after the test sequence.

IRt/c's Withstand 1000G Shock

Tech Note
79

With simple "O-ring" mechanical supports, IRt/c's can withstand up to 1000 g shock without damage, and *without shift in calibration*. Such robustness makes them well suited to heavy duty applications where high levels of shock and vibration are common.

More modest forces of 10 g can be withstood on a continuous basis, but fatigue of the cable can be a problem. Mechanical support, coiling, or other appropriate cable management is recommended.

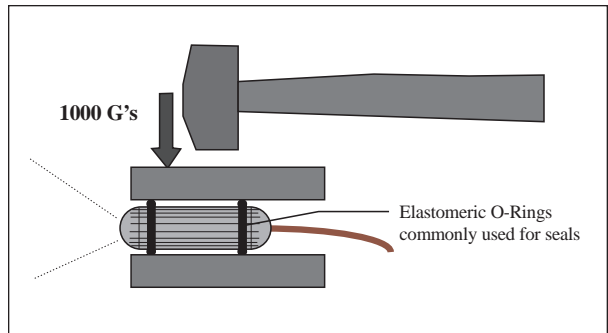

Unique "Slot Spot" IRt/c's Measure Small Rectangular Spots

Tech Note
80

IRt/c.2/15ACF-HiE for Non-Metal Targets, 0 to 2500 °F (-18 to 1370°C)

IRt/c.2/15ACF-LoE for Metal Targets, 500 to 2500 °F (260 to 1370°C)

Specifically designed for measuring temperatures of very small objects, the unique *Slot Spot* IRt/c makes it possible to monitor and control such difficult targets as small extrusions, yarn, thread, wire, glass fiber, and others.

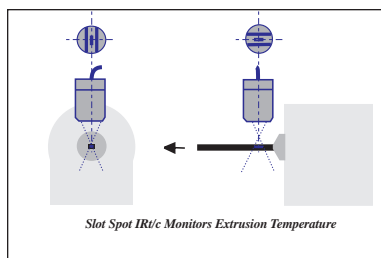
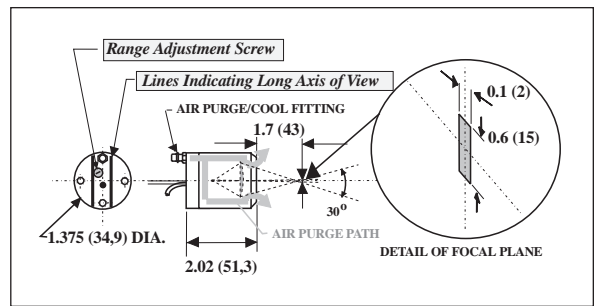

Slot Spot IRt/c Monitors Extrusion Temperature

To use, follow all of the standard set-up and calibration instructions supplied for all of the adjustable IRt/c models. Use the lines scribed on the

back of the sensor to align the field-of-view on the target. The alignment can be fine-tuned by moving the sensor (closer, farther, rotate slightly) until a maximum signal is obtained. For convenience a

handheld t/c meter or millivolt meter can be used. The sensor is positioned optimally when the maximum signal is obtained on the meter.

The Aperture Kit provided with the sensor may be used to extend the temperature range, or improve the resolution of adjustment. The wide linear range calibration technique specified in Tech Note 70 is recommended. The table shows the temperature limits for each aperture.

For monitoring targets which are outside the focal plane, the field-of-view can be approximated by intersecting planes in both views with an included

continued...

Aperture	None	1/2" (13 mm)	1/4" (6 mm)
IRt/c.2/15ACF-HiE (Non-Metal Targets)	0 to 700°F (-18 to 370°C)	500 to 1500°F (260 to 820°C)	1300 to 2500°F (700 to 1370°C)
IRt/c.2/15ACF-LoE (Metal Targets)	500 to 1400°F (260 to 760°C)	1200 to 1800°F (650 to 980°C)	1600 to 2500°F (870 to 1370°C)

angle of approximately 30°. This results in one-half of the distance from the focal plane being added to each dimension. For example, if the target is 1" (25 mm) from the focal plane, 1/2" (13) would be added to both dimensions, resulting in a spot size 1.1" (28) long by 0.6" (15) wide. This feature makes the *Slot Spot* particularly well suited to monitoring temperature of a target through any opening that is slot-shaped.

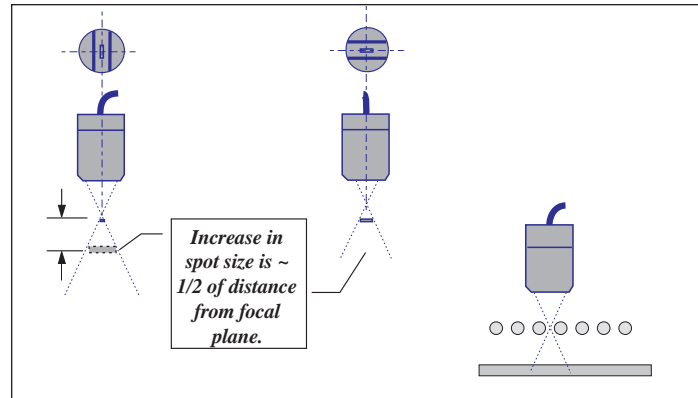

Tech Note

81

Side View Model Designed for Monitoring Web Processes

IRt/c.SV

In heating, drying, coating, cooling, or any other thermal processing of webs of paper, plastic, metals, textiles, film, etc., often there is very little space available for a sensor to monitor web temperature. In a space as small as 0.56 in. (14.2 mm) the IRt/c.SV Infrared Thermocouple can be installed to monitor temperature of the moving web, and reliably control the process to maximize quality and throughput of product.

The IRt/c.SV has all of the same specifications as the standard IRt/c, including no power requirement, rugged stainless steel hermetically sealed construction, intrinsically safe, full electrical shielding, ~0.1 second response time, and ability to operate uncooled in environments up to 212°F (100°C). It is available in J,K,T,E thermocouple types, with linear range selections the same as the standard IRt/c. The solid filled 1/2 in. (12.7 mm) tubular housing can be held securely with convenient tube fittings or standard clamps to mount the sensor over the target area.

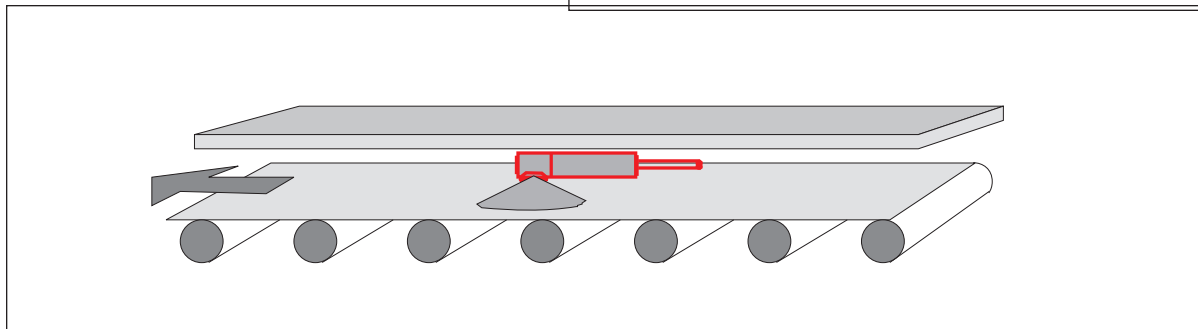
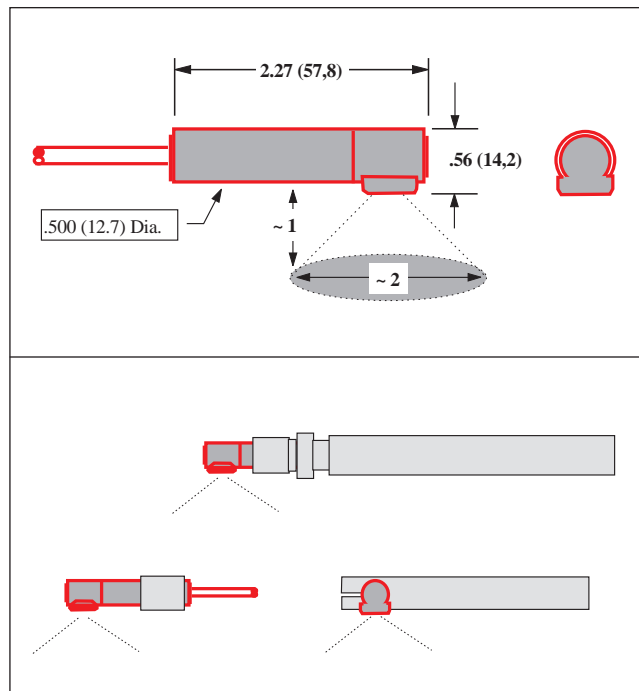

Grounding and Shielding for Electrostatic Protection and Noise Suppression

Tech Note

82

Applies to All Models With Stainless Steel Housing

All IRt/c models with stainless steel housing are built with complete electrical shielding of both the housing and cable, with the measuring elements electrically isolated from the housing (as in a conventional **ungrounded** thermocouple). By adhering to standard good practice in grounding and shielding techniques, IRt/c's can provide outstanding performance in the most severe electrical environments commonly found in production processes.

Q. When is attention to grounding and shielding required?

A. If the IRt/c must operate in extreme environments, employ long t/c cable runs, the measuring system is utilizing the high speed capability of the IRt/c, **or if the process can generate high static electricity fields**. For most installations, the built-in noise rejection characteristics of the IRt/c are sufficient to insure good performance, especially if the readout device is heavily filtered with a long input time constant.

Q. Can I operate ungrounded?

A. Yes, but it is not recommended, especially in applications where the process can generate **high static electricity fields**. Examples are web processes of all types, including printing, laminating, film drying, etc. Without either the housing or shield grounded to drain away the charge, a static charge can build in the housing, which may eventually discharge through the IRt/c sensing elements, and can cause damage to the sensor.

Q. How do I use the shield correctly?

A. The most important rule is to be sure the shield is grounded at only one point, preferably at the signal input ground. Keep in mind that the housing is connected to the cable shield, and if the housing is electrically in contact with machinery at the mounting point, that point will be a ground, and the shield wire should not be connected at the instrument end.

For best possible performance, electrically isolate the IRt/c at the mounting point and ground the shield at a suitable ground on the readout instrument.

Q. Can I ground the shield to the negative (red) thermocouple lead instead of to a chassis ground?

A. Yes, but test both alternatives in your application and use the one that gives the cleanest signal. Be sure that the housing is electrically isolated, otherwise ground loop currents may cause errors.

Q. Should the extension cable be shielded?

A. As indicated above, if the installation requires high speed performance, twisted shielded extension cable and connectors with ground straps should be used throughout. Aluminum foil is a suitable material to complete a shield if there are gaps in the shield coverage.

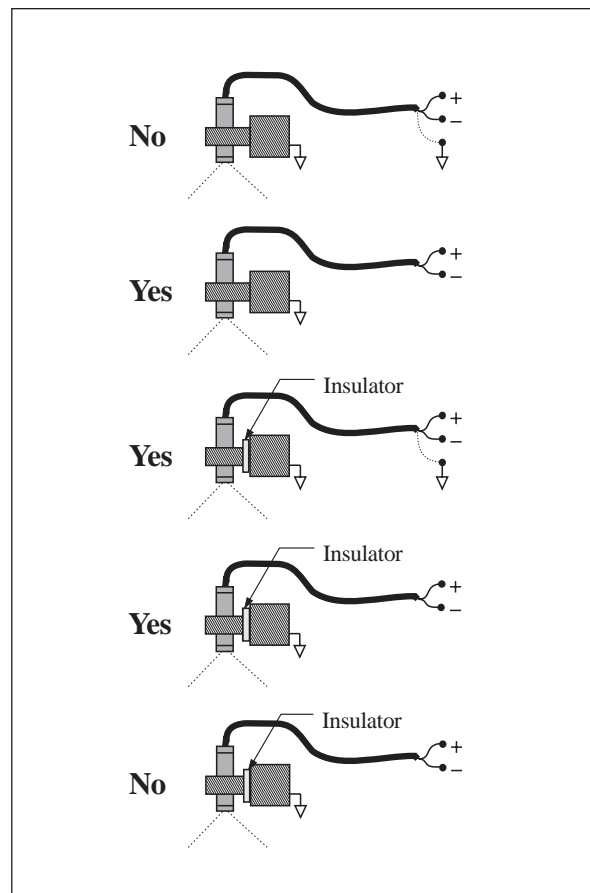

Side View Model Designed for Monitoring Temperature in Dirty or Vapor-Filled Environments

IRt/c.3SV

In heating, drying, coating, cooling, or any other thermal processing of webs of paper, plastic, metals, textiles, film, etc., often there is very little space available for a sensor to monitor web temperature, and the harsh environment requires a highly efficient air purge design to prevent fouling of the IR lens. In a space as small as 0.7 in. (18 mm), and in areas where ink or paint are being applied, the IRt/c.3SV Infrared Thermocouple can reliably control the process to maximize quality and throughput of product.

The IRt/c.3SV has all of the same specifications as the standard IRt/c, including no power requirement, rugged stainless steel hermetically sealed construction, intrinsically safe, full electrical shielding, ~0.1 second response time, and ability to operate uncooled in environments up to 212°F (100°C). It is available in J, K, T, E thermocouple types, with linear range selections the same as the standard IRt/c. The solid filled 1/2 in. (12.7 mm) tubular housing can be held securely with convenient tube fittings or standard clamps to mount the sensor over the target area.

Ideal applications are offset printing, where the presence of inks and physically tight locations make the IRt/c.3SV the sensor of choice. Targets that must be monitored “upside down” are also ideal applications, since the narrow field of view and air purge will prevent debris from blocking the lens. Only 5 psig (.3 bar), which consumes less than 1 SCFM (.03 m³/min) is required for direct paint spray environments.

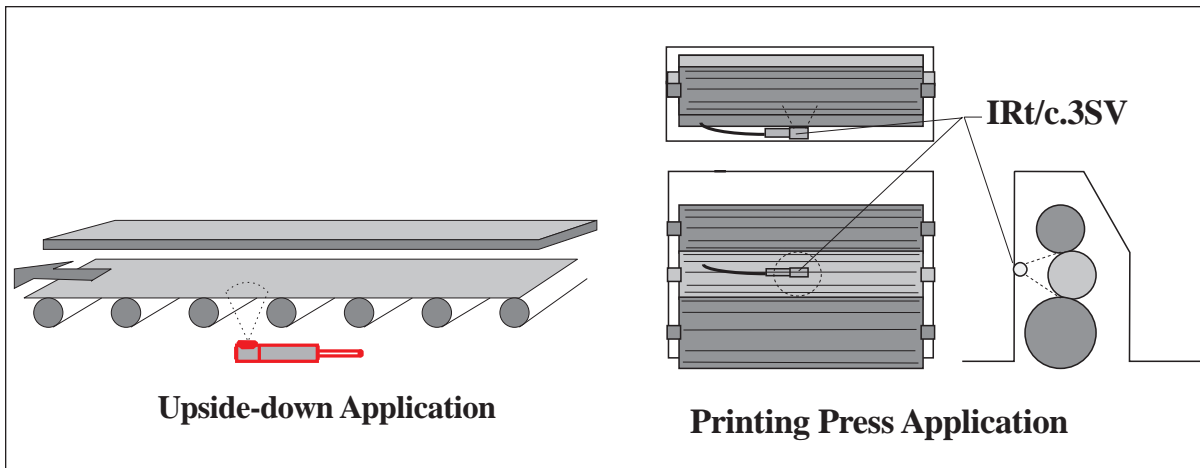
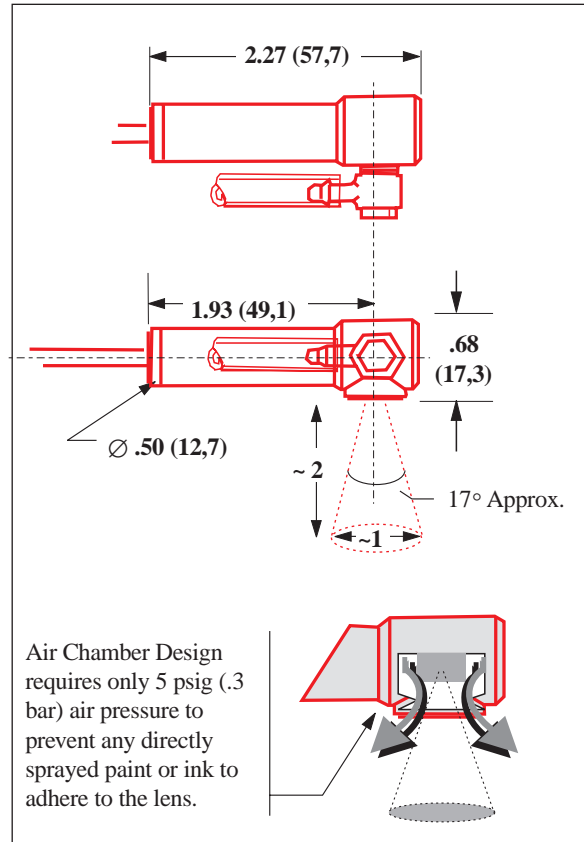

Using the IRt/c.01 in a High Electrical Noise Area

Tech Note

84

Applies to All Models With ABS Plastic Housing

In applications where the low cost of the IRt/c.01 is important, and the other performance requirements are met by the sensor, there are occasional concerns that electrical noise in the environment can affect the readings. By employing one or more standard techniques, IRt/c.01's can provide outstanding performance in the most severe electrical environments commonly found in machinery.

1. Employ Filtering in the Readout Device.

If the readout device is heavily filtered with a long time constant, there is normally never a problem with noise. Response time constants in the range of 1 second are in common use in temperature controllers, and are usually more than enough to prevent any significant noise interference.

2. Add a Shield to either the IRt/c.01 or the EMI Source.

With aluminum foil, conduit, etc. the IRt/c.01 can be

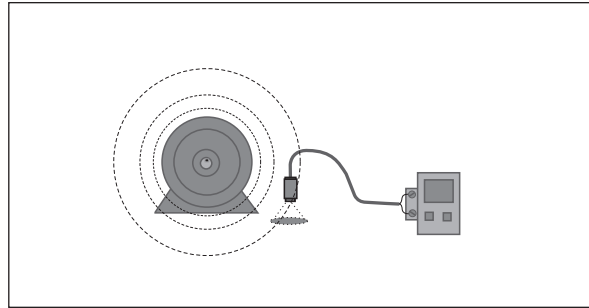

shielded from the source of electromagnetic radiation directly. Be sure to properly ground the shield. Refer to Tech Note No. 82 for recommendations.

3. Consider Substituting a Fully-Shielded IRt/c Model.

If none of the above options provide the necessary performance, especially for high speed applications, select one of the fully shielded stainless steel IRt/c models for the application.

IRt/c.01 Selection and Application Hints for OEMs

Tech Note

85

To assist you in specifying an IRt/c.01 model for your application, the following sequence of steps is recommended:

Locate the IRt/c.01 close enough to make the measurement accurately.

Referring to the 1:1 field-of-view specification, be sure that the target is large enough, or the sensor close enough such that the target is *larger* than the measuring spot. The IRt/c.01 can be physically close as to nearly touch the target, and is limited only by physical space and local temperature. Normal mounting is with the supplied locknuts (2 supplied), but alternative methods may be used to hold the cylindrical section or the flats, whichever is more convenient in locating as close as practical. For hot targets in close proximity (~ 1 inch or 2.5 cm) permit adequate ventilation of the mounting to keep the IRt/c.01 below its 160°F (70°C) rating. If the sensor face is likely to become dirty, mount in such a fashion to permit occasional cleaning with a mild solvent such as alcohol.

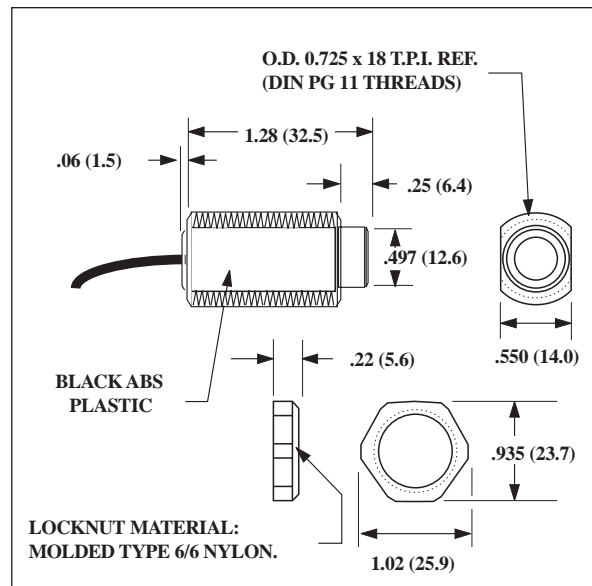

Select the linear range required.

Referring to the Temperature Selection Guide, choose the model that has the center of its linear range closest to the control point for your application, and select the thermocouple type you prefer. If your application includes monitoring and control over a range of more than ~ 100°F (~ 50°C), and your thermocouple interface has computational ability,



request a copy of the IRt/c Signal Output Table for your model, which has the data necessary to linearize over the entire operating range of the IRt/c.01.

Calibrate just once!

Referring to Tech Note No. 1, best practice is to install the IRt/c.01, operate the process under normal conditions, and calibrate the read-out system based on the reading from a reliable reference (the D-Series is recommended). As long as the target materials are consistent, and there is no leakage current offset from the electronics, the initial calibration will be valid for all subsequent installations.

Tech Note

86

Inexpensive Infrared Scanning Arrays with IRt/c.01

For web drying, printing, laminating, paint curing, etc.

With the low cost of the IRt/c.01 and its direct compatibility with inexpensive, widely available thermocouple input devices, powerful infrared scanning arrays can now be considered for applications in which thermal signatures are desired for process monitoring and control. Such applications include web drying, printing, laminating, paint curing, and any other thermal processing of moving material. Multiple input monitoring and control devices include data acquisition systems, personal computers, PLC's, and custom OEM cards. By taking advantage of the low cost performance of the IRt/c.01 and standard available components, infrared scanning arrays can be put to work controlling your process for approximately \$100 per channel.

Some tips on setting up an IRt/c infrared scanning array:

Be sure to use identical models for each sensor in an array.

This will keep all of your signals internally consistent within the software you use, and avoid any interpretation errors. Also, if you employ the available IRt/c Signal Output Tables, one table or curve will apply to all the sensors in an array. IRt/c's of the same model are interchangeable to < 1% of reading.

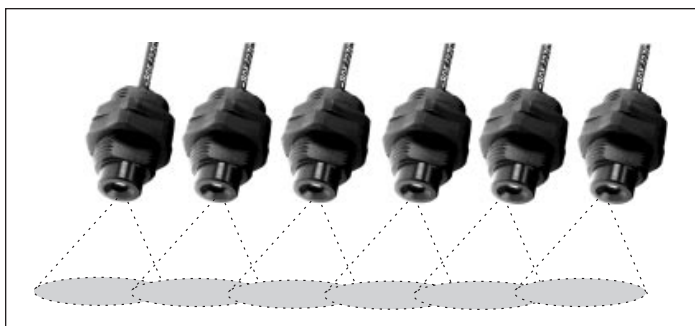

Investigate low cost thermocouple interfaces.

Prices per channel for computer A/D cards and PLC input cards for thermocouples have fallen to well under \$100, and are available for as little as \$30 for some systems. If the application is for high volume OEM equipment, consider using a board-level chip such as the Analog Devices AD594/5, available at under \$7 (see Tech Note No. 72).

For single channel use, consider IRt/c's in parallel.

Wired in parallel to a single input channel, an array of IRt/c's produces an output signal which indicates the *average temperature* of the targets scanned. This attribute is particularly convenient for monitoring and controlling wide webs, which cannot easily be covered by a single sensor. To use, simply wire all of the red (-) t/c leads to the negative input terminal, and the other (+) leads to the positive input.

Two-Color Pyrometry with IRt/c's

Tech Note

87

The IRt/c.L2 Method

For many bare metal temperature monitoring applications, emissivity variations are too extreme for even the IRt/c-LoE models to provide reliable information. A common problem is aluminum, since emissivity is low and variable due to alloying, surface oxidation, surface finish variations, etc.

The traditional non-contact infrared solution has been two-color pyrometry, since this method yields significant improvements over single wavelength devices by ratioing signals at two nearby wavelengths, and thus deducing temperature from the ratio. The major drawbacks of conventional two-color systems are size, complexity, and cost. The IRt/c innovation, and the availability of inexpensive computational power, have made possible a simple, reliable substitute for conventional two color pyrometry at a small fraction of the cost and small fraction of the size.

The IRt/c.L2 method of two-color pyrometry incorporates the following:

- A short wave (LoE) IRt/c model and long wave IRt/c model viewing the same target area.
- Two thermocouple input channels to a computer or PLC.
- Computational ability to solve two equations in two unknowns on-line.

Depending on the models selected, the cost for such a system can be well under \$1000.

The equations to be solved are as follows:

For the short wave (LoE) model:

$$S_{SW} = A(\epsilon/.25)(1.771E-17 T^6 - 6.584E-14 T^5 + 2.062E-10 T^4 + 1.625E-07 T^3 - 5.366E-05 T^2 + 1.116E-02 T - 8.615E-01)$$

For the long wave model (example IRt/c.2-K-440F/220C):

$$S_{LW} = (\epsilon/.9)(-5.335E-16 T^6 + 8.684E-13 T^5 - 4.670E-10 T^4 + 4.446E-08 T^3 + 8.892E-05 T^2 + 1.622E-02 T + 1.300E+00)$$

where S_{SW} and S_{LW} are signals produced in millivolts (referenced to 0°C cold junction compensation), ϵ is emissivity, T is target temperature, and A is an arbitrary calibration constant that represents the position of the adjustment screw for the adjustable LoE model.

IRt/c.L2 Method uses energy content of two wavebands to calculate temperature: a short wave band which is strongly sensitive to temperature and weakly to emissivity; and a long wave band strongly sensitive to emissivity and weakly to temperature.

An initial calibration has to be performed with both devices viewing the same known target temperature. The value for ϵ is immediately computed by the S_{LW} equation, and the value for A by the S_{SW} equation. A variety of computational methods can be employed to compute ϵ and T continuously from the two equations in two unknowns, with the simplest

being a computation of differentials in signal relative to the initial calibration. The only assumption required for the method to work in its differential form is that the ratio of emissivities for the two wave bands employed remain constant, i.e. $(\epsilon_{SW}/\epsilon_{LW}) = \text{constant}$. For the example and recommended combination of IRt/c.10A-LoE (short wave), and IRt/c.2-K-440F/220C (long wave) these wavelength bands are 0.1 to 5

micron and 6.5 to 14 micron respectively. Note that the emissivity coefficient can include any effect that is not wavelength dependent, such as intervening dust, partial obstruction, or target smaller than the fields-of-view.

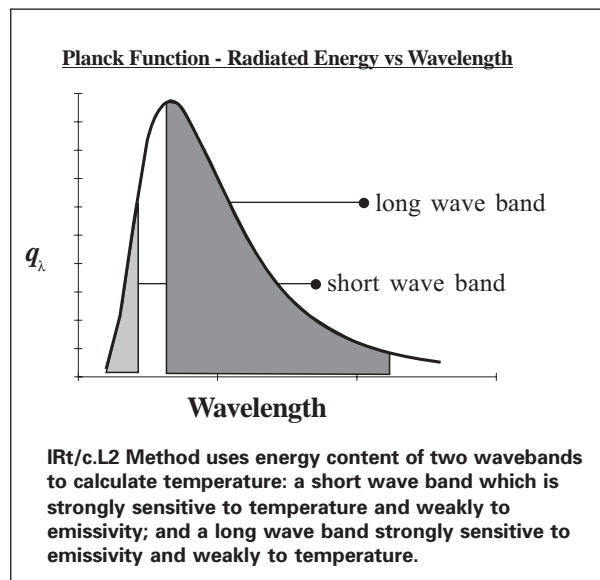
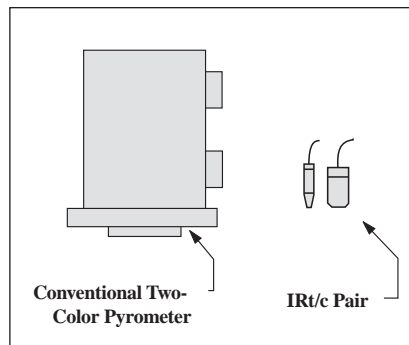

Measuring Tire Tread Internal Temperature

with the IRt/c-HB (Heat Balance)TM Series Infrared Thermocouple

Model IRt/c.5-HBT-J-80

By its very nature, infrared measures *surface* temperature, but most material properties of interest relate to *internal* (bulk) temperatures. For many materials, such as metals, the gradient between the surface and internal temperatures is small enough to ignore. For other materials, such as rubber products, the gradient can be quite large when the

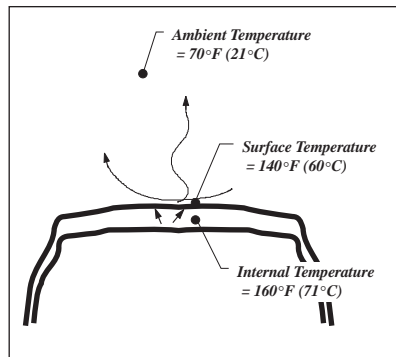

material is exposed to an ambient temperature that is much different from its bulk temperature. This problem is particularly acute in the manufacture and testing of tires, since surface temperature may not be a reliable indication of internal tread temperature, which is the property of interest, due to the action of rapid convection and radiation at the surface, and slow conduction internally.

The IRt/c Heat Balance Series Infrared Thermocouples actually calculate the internal temperature by solving the equation that describes the heat balance between internal, surface, and ambient temperatures, and produce an *unpowered thermocouple signal that represents the internal temperature!*

This breakthrough method was first developed and patented by Exergen Corporation for use in the medical field to solve the problem of obtaining human core body temperature non-invasively, and is in use in literally hundreds of

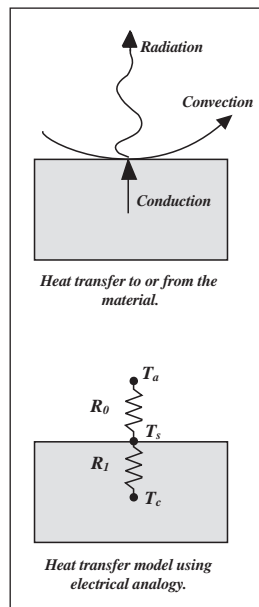

thousands of clinical infrared thermometers. The application to tire temperature measurement is the first industrial application of the method.

Mathematically, the IRt/c-HB employs what is called the *Heat Balance Equation*, which follows from the basic heat transfer electrical analog circuit shown:

$$T_c = K(T_s - T_a) + T_s$$

$$\text{where } K = \frac{R_1}{R_0}$$

The *Heat Balance Equation* is continuously solved by the IRt/c, and produces a thermocouple millivolt signal that represents T_c . For the IRt/c.5HBT-J-80, the signal is a type J, and the K is programmed to calculate temperature approximately 1/4" (6 mm) deep.

All of the other outstanding characteristics of the IRt/c, including unpowered simplicity, rugged hermetically sealed system, intrinsic safety, and compatibility with standard thermocouple interfaces with PLC's, computers, controllers, etc., makes the *Heat Balance Series* an outstanding selection for the measurement of tire temperature, and the improved performance made possible by accurate measurements.

Set-up and Calibration

System set-up and calibration is the same as for all other IRt/c models except that the reference temperature is obtained with a probe type unit to

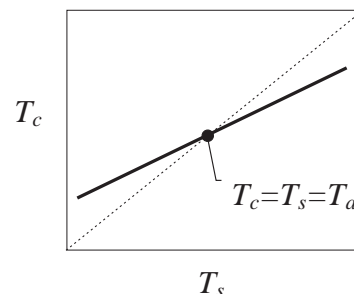
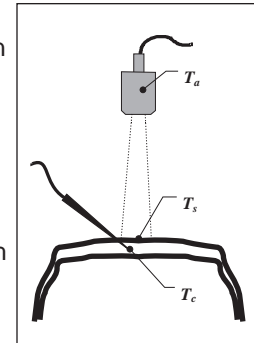

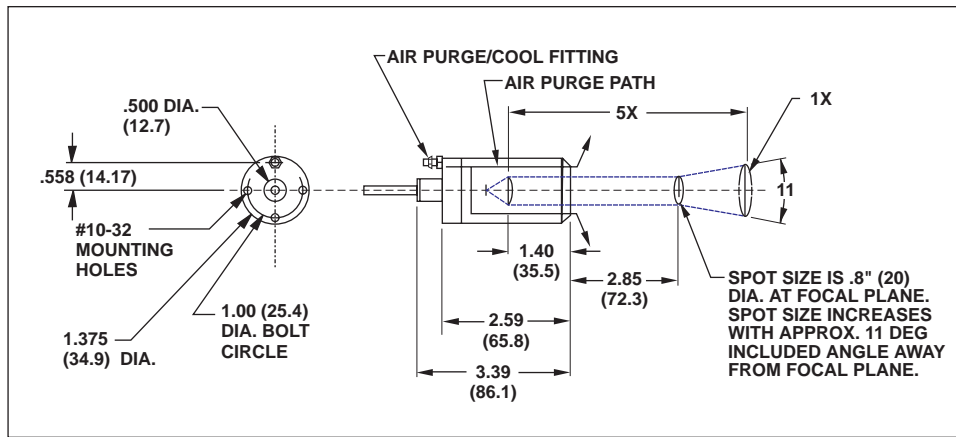

penetrate to the depth of measurement. Following Tech Note No. 1, the process is as follows:

- Install the IRt/c in the location it will be used.
- Wire IRt/c to readout device.
- Place tire to be measured in normal location. Tire temperature must be significantly different from ambient for the calibration to be accurate.

- Measure internal temperature with insertion probe.
- Adjust readout device OFFSET, or ZERO until IRt/c reading agrees with probe.

Calibration complete.

The new technology embodied in the IRt/c Heat Balance Series can be used in other applications where internal bulk temperature is required.

IRt/c Specifications: Real World Performance Accuracy

Tech Note

89

The table below summarizes some of the major differences between how IRt/c's are designed and calibrated, compared to conventional infrared devices, with the objective of providing the best possible accuracy under actual real-world conditions.

Why the IRt/c is Different

The concept of a black-body is a highly useful and essential mathematical construction in the application of infrared radiation physics, and has had firm theoretical support from the time of Max Planck nearly 100 years ago. However, in the real world application of infrared methods for temperature control, IR devices do not measure black-bodies.

More realistically, real-world measurements are performed on targets that approximate what is termed a gray-body, i.e. materials which have an emissivity less than 1. Gray-bodies also have the further characteristic that emissivity is constant at all wavelengths of interest. Then for gray bodies:

$$q_{gb} = q_{bb} \epsilon$$

at all wavelengths, where q_{gb} and q_{bb} are radiated energy from a gray-body and black-body respectively.

An important element which is missing when working with black-bodies, but present with gray-

continued...

	IRt/c	Conv. IR
Designed and calibrated to black-body conditions?	No	Yes
Designed and calibrated to real-world conditions?	Yes	No
Calibrated with multiple gray-bodies?	Yes	No
Calibrated with multiple ambient temperatures?	Yes	No
Constructed to minimize ambient reflective errors?	Yes	No
Designed to minimize emissivity shift errors?	Yes	No
Calibrated with NIST traceable standards?	Yes	?

Radiated Energy vs Wavelength

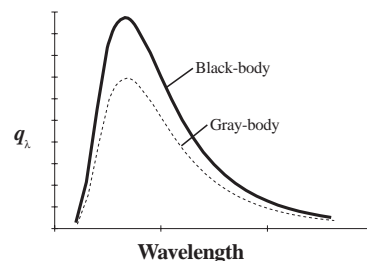

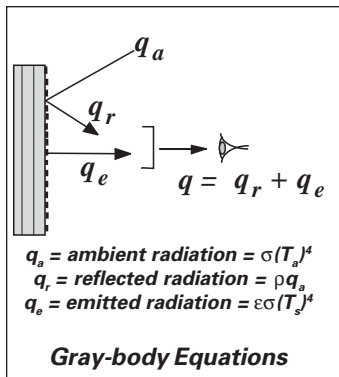

bodies is reflected radiation. For non-transparent materials, emissivity plus reflectivity always equals one:

$$\epsilon + \rho = 1$$

Accordingly, for a black-body $\epsilon = 1$, and therefore $\rho = 0$. But for a gray-body

$\epsilon < 1$ and therefore $\rho > 0$, and the reflected radiation due to ambient temperature must be considered. Refer to Tech Note No. 64 for further details.

IRt/c's are specifically designed to be accurate and reproducible under real world conditions of targets that approximate gray-bodies, with ambient temperatures that vary, thus with reflected radiation that varies. The performance specifications of the IRt/c, unlike conventional infrared devices, include gray-body effects.

Mathematically the signal output of an IRt/c is a complex function of target temperature, ambient temperature, target emissivity, reflected energy, thermocouple type, etc. To clarify the specifications we can represent the change in signal with respect to a variable of interest, while holding all other variables constant, as a partial derivative.

Ambient Temperature Coefficient Specification

The variation in output signal with ambient temperature, which is the Ambient Temperature Coefficient specification, can be represented as below:

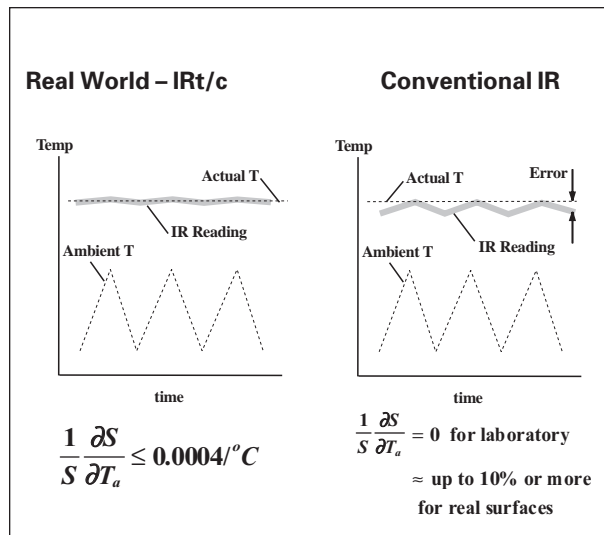

where S is the output signal and T_a is the ambient temperature. This equation describes the output of the IRt/c, including a gray-body assumption of emissivity = 0.9, and that the sensor itself is at the same temperature as the environment.

What this means in practice is that when an IRt/c is installed and calibrated in place (Tech Notes No. 1, 64), the IRt/c body tends to change temperature with the ambient background that the target sees, then internally applies the correction required to reduce errors. Without this feature this error could be many times higher, and cause unwanted shifts in process control temperature.

For example, waterless printing processes require that the ink application roll to be temperature controlled in order to maintain high quality. If the temperature is to

be controlled at 80°F (26.7°C), and the press enclosure can vary over the range 70 to 100°F (21.1 to 37.8°C) due to warm-up, weather, air ventilation, etc.; then a conventional IR device will produce an error of about 3°F (1.7°C), while an IRt/c will produce an error of only 0.2°F (0.1°C).

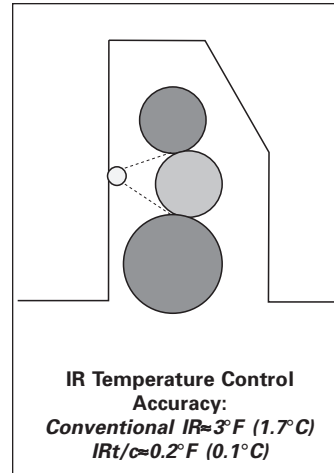

Thus, the IRt/c provides ten times more accurate control than the conventional device.

To estimate the improvement in control accuracy produced by the IRt/c for a specific application, the following approximation can be applied:

$$\text{Error with Conventional IR} \approx (1 - \epsilon)(\Delta T_a)(T_s - T_a)$$

$$\text{Error with IR t/c} \approx (0.9 - \epsilon) \left(\frac{\Delta T_a}{10} \right) (T_s - T_a)$$

Compensating for Emissivity Variations

A common assumption for conventional IR thermometry is that emissivity is constant with changes in target surface temperature. Real materials do not have this characteristic. The average value for non-metals for which the change in emissivity with respect to surface temperature has been reported, is approximately - 2% per 100°F target temperature change (- 3% per 100°C).¹

Applying the partial derivative mathematical formulation, the emissivity variation is:

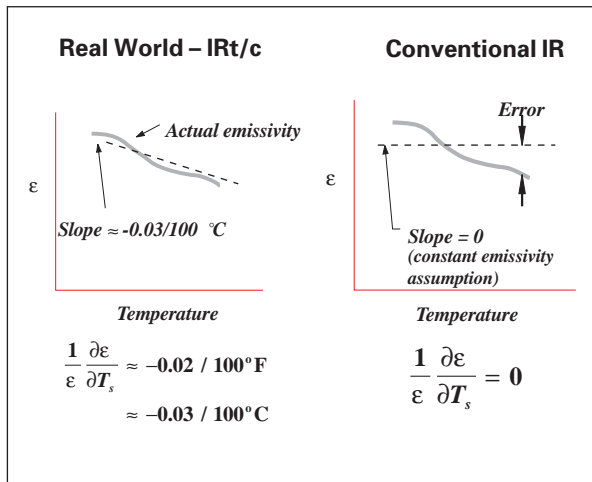

Conventional IR misses this effect, and will cause process control errors.

The signal produced by the IR device is proportional to the radiation emitted by the surface:

$$S = \epsilon q_{bb} \text{ (conventional IR assumption)}$$

then the change in signal with respect to target surface temperature may be presented as follows:

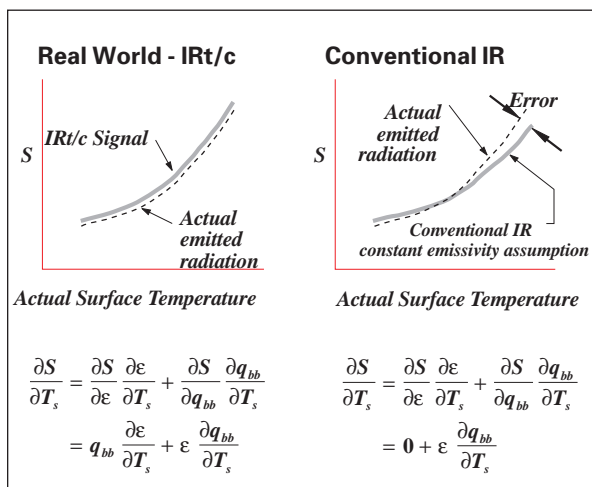

Note that the conventional IR device loses one term of the signal change with respect to surface temperature. When the IR signal is converted to a temperature indication, the signal in the conventional device is linearized, whereas in the IRt/c the signal is unchanged.

Since real-world emissivity for most non-metal materials decreases with temperature, the constant emissivity assumption of conventional IR devices produces errors in readings that are not obvious to the typical IR user and can be highly misleading over a wide temperature range. The IRt/c, however, is specified for a useable specific temperature

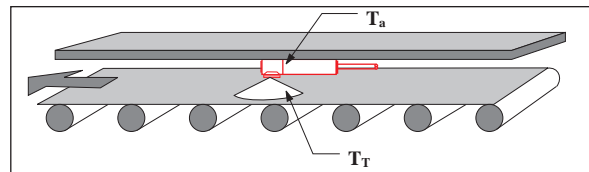

range, where the effect of emissivity change is accounted for in the linearity specification, and the user is confident that his process control will be accurate. Note that testing an IRt/c with a black body will not give the same linear range as a real-body.

A second effect on linear range is the effect of target surface temperature on ambient temperature, and therefore the reflected component of radiation to the sensor. As target temperature increases within a process, the increased radiation heat transfer to the surroundings will cause the target ambient radiant background to also increase in temperature.

For example, a laminating process that has several temperature control settings that depend on the material and feed speeds, may operate with target temperatures that are 100°F (56°C) different. As the material changes temperature, the background radiation in the vicinity of the measurement will also change temperature, and influence the IR reading.

Accordingly, the variation in signal with target temperature has the additional component as follows:

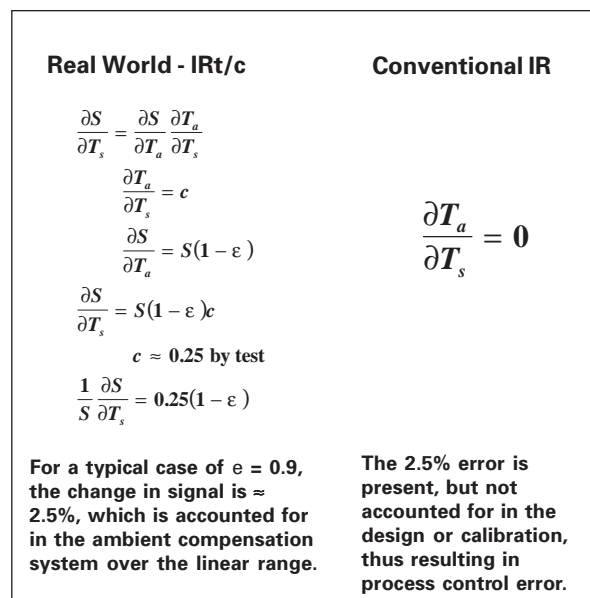

Comparison to Standard Thermocouples

Standard thermocouples are generally specified as adhering to ASTM and ANSI specifications, which prescribe a basic accuracy of $\pm 2.2^\circ \text{C}$, or 0.75% of

continued...

reading, whichever is higher². Likewise, IRt/c's are also specified to be within the same $\pm 2.2^\circ\text{C}$ limits, or to the percentages stated in their specifications, whichever is higher.

However, it is important to note that *when an IRt/c is calibrated to installation, this error disappears.*

Repeatability and Interchangeability

The cardinal requirement for the IRt/c, as in any measuring device, is to repeat its calibration. The *repeatability* of IRt/c's is specified at $<0.1^\circ\text{C}$.

Interchangeability uncertainty from one device to another is *2% maximum*, since each individual device is built and tested to conform to standards with a $\pm 1\%$ tolerance, so is therefore able to produce a maximum of $\pm 2\%$ difference between any two devices. *Typical* interchangeability uncertainty, determined by test, is described statistically with standard deviation of approximately 0.5°C .

Summary

1. The IRt/c is a different type of device compared to conventional IR, since it is carefully designed and built to produce real world accuracy for temperature control, with some subtle features that make a significant improvement over conventional IR.
2. In-place calibration is always recommended, as it always is with any IR device due to uncertainties in emissivities and ambient temperature.
3. For OEM applications, or multiple same-use applications in a factory, once the initial system has been qualified and calibrated, IRt/c's of the same model can be substituted without the necessity of recalibration.
4. An added benefit of the IRt/c is its *specified useable linear range* per model. (A user is not led into believing that his measurement is
5. An IRt/c's full performance *cannot be accurately checked with a black-body*. Standard laboratory black-bodies can be used for pass-fail or reproducibility testing only. Contact Exergen for availability of specialized test devices.
6. An IRt/c's full performance *cannot be accurately checked with a conventional handheld portable IR device*, there are too many external sources of error. See Tech Note #91.

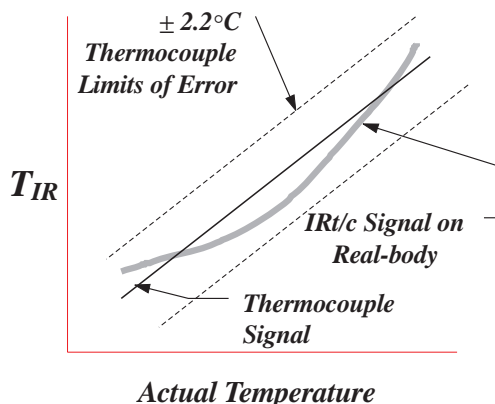
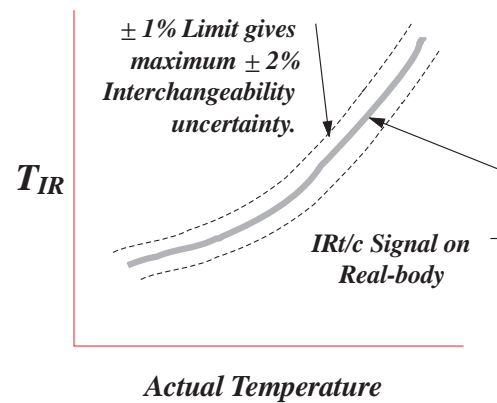

Notes

1. Thermal Radiative Transfer and Properties, MQ Brewster ed., John Wiley & Sons, 1992.
2. ASTM Standard E230, ANSI MC96, Manual on the use of Thermocouples in Temperature Measurement, Fourth ed., ASTM 1993.

IRt/c's More Accurate than Conventional IR in Real World

A common misunderstanding amongst even experienced manufacturers and users of infrared temperature measurement equipment is that *the accuracy of temperature measurement is solely a specification of the infrared device*. This statement is correct only in the laboratory under controlled conditions with blackbody (emissivity = 1.0, reflectivity = 0) targets. In the real world, designs and specifications that are applicable in the laboratory can be misleading and sometimes outright incorrect. Following is a summary of the key points of accuracy in a comparison between the IRt/c and conventional IR (detailed mathematical development is presented in Tech Note No.89).

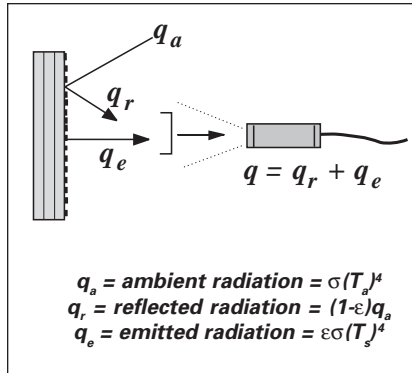

- 1. Real-world materials have emissivity < 1, and therefore have reflectivity > 0, which causes errors from varying background temperatures.**

Even non-metals, with emissivity approximately 0.9 and reflectivity approximately 0.1, must reflect about 10% of the energy incident from the background ambient. This reflected energy, unrelated to the target temperature, is nevertheless measured by the infrared sensor, and therefore will introduce significant errors if the ambient temperature changes, as it does in the real world. Conventional IR devices, calibrated with blackbodies, usually ignore this effect, and thus are subject to the error. IRt/c's are specifically designed and tested to include a correction for this effect and thus improves their real-world accuracy.

- 2. Real-world materials have emissivities that change significantly with temperature, which causes significant errors even with perfect calibration and linearization.**

Probably the most misleading concept in infrared thermometry is that emissivity is constant with varying temperature. Real-world materials have emissivity variations that range from an average of 2%

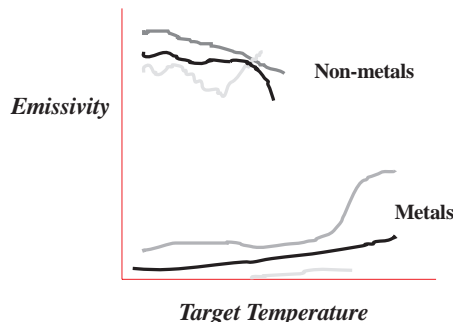

per 100°F (60°C) temperature change for non-metals, to 10% per 100°F (60°C) temperature change for some paints, and well over 100% per 100°F (60°C) temperature change for some metals.¹ Accordingly, accuracy of real-world temperature measurements should be considered valid only for a limited temperature range.

Specifications of accuracy for conventional infrared devices specified over wide target temperature ranges are largely meaningless. (The sole exception is Exergen's D-Series, due to its Automatic Emissivity Compensation System.)

IRt/c's are specifically designed and tested to maintain very high accuracy over a limited temperature range, and *specifically not*

specified to imply accuracy over a wide target temperature range. For this reason IRt/c's are offered in a variety of temperature range selections, each of which is optimized for a specific limited temperature range, which correctly reflects the real-world material characteristics, and maximizes the accuracy.

- 3. Real-world temperature control is most accurate if the IR sensor is designed, built, calibrated, and tested at factory conditions that are designed to reflect actual field conditions.**

Conventional IR devices are designed, built, and tested to standards traditionally defined by blackbodies, which do not include the errors caused by reflected energy and emissivity variations of real-world materials. IRt/c's are designed, built, and tested to standards that include elevated and variable ambient background temperatures, and real-world target materials that change emissivity with temperature, thus maximizing the accuracy of temperature measurement and control.

1. *Thermal Radiation Heat Transfer*. R Siegel and JR Howell, ed., second edition, Hemisphere Publishing Corporation 1981.

Disposable Window

A not uncommon problem in some industrial environments, such as foundries, is maintaining optical cleanliness during washdown, or protecting the lens from debris when air purge is impractical or insufficient. In addition, sometimes a barrier is necessary between the process to be monitored and the IRt/c.

Windows made of common materials such as glass, etc. will significantly attenuate infrared radiation from targets below about 1000°F (540°C) and are not generally suitable for low temperature service.

However, windows made of polyethylene will transmit very efficiently at all temperatures if they are thin enough. "Thin" means generally less than about 0.005 in. (0.1 mm).

An excellent material is a commonly available plastic wrap brand called *Glad Cling Wrap®*, which can

easily be wrapped around the IRt/c for cleanliness, or formed into a window. If the polyethylene is dirty or damaged, it can easily be replaced. With maximum temperature rating at about 212°F (100°C), this material can be used in many processes.

The transmission coefficient of such thin polyethylene is in the neighborhood of 90%, and therefore only a small recalibration of the readout device may be required. Other brands of plastic wrap are not recommended, unless you can confirm that they are made from polyethylene.

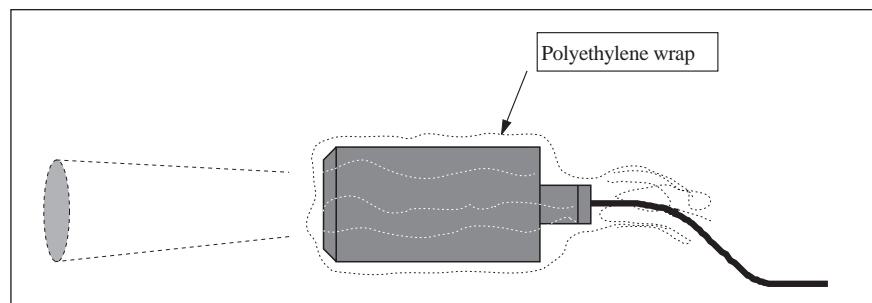

Drying Paper Webs With Jets of Air Controlled by IRt/c's

A basic problem in controlling moisture content of paper webs is non-uniformity of drying across the web. Standard methods cannot address this problem because typically the entire web is measured for moisture content, and the process is adjusted to insure that no part of the web has too much or too little moisture. Accordingly, the overall basis weight and paper properties are not optimum, since there are significant non-uniformities. IRt/c's, along with inexpensive PLC's or other computing power, makes it possible to eliminate these non-uniformities and maximize the value of the paper.

The method consists of spanning the web with a series of simple modules consisting of an IRt/c and a controllable air jet configured to dry the strip scanned by the IRt/c. The IRt/c signal is the input to a temperature control system which controls the air jet based on local temperature and other process

parameters. By individually drying each strip to the same standard, the web can maintain uniformity and therefore high quality. Any IRt/c model with built-in air purge is suitable. Where mounting space permits, the IRt/c.5 sensor is the recommended model.

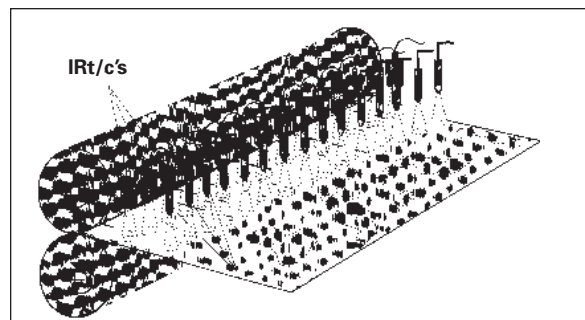

In-line Pre-Calibrated Transmitter for Easy, Reliable Installation

Model t/c.XMTR- * - ** 4-20 mA Transmitter

Current loop transmitters for thermocouples have traditionally been designed as “hockey pucks” in order to fit thermowell heads, thus complicating installation for applications not using a thermowell, and requiring a housing for protection. Additionally, they generally have to be calibrated to a specific range, usually with thermocouple simulators or other such device, thus requiring significant set up time and the possibility of unauthorized recalibration.

The t/c.XMTR is designed to overcome both of the costly inconveniences:

- In-line design is only slightly larger than the cable and requires no mechanical support.
- Precalibrated for thermocouple type and temperature range eliminates all adjustments, requirements for simulators, etc.
- Hermetically sealed stainless steel construction is suitable for the harshest service without any additional packaging.

The t/c.XMTR is specifically designed to interface to any model IRt/c (or any conventional thermocouple) by a simple thermocouple connector or splice. The 2-wire current loop can be used in any conventional current loop circuit that is scaled for the temperature range of interest.

Model Selection

1. Select the correct IRt/c model for the application: target temperature, target material, field-of-view.
2. Select the t/c.XMTR model for the t/c type and temperature range from the table below. Example: t/c.XMTR-K150

Installation

1. Install IRt/c as normal.
2. Connect IRt/c output cable to the thermocouple input side of the transmitter using standard t/c connector, splice, or other standard method of connecting thermocouple cables. Trans-

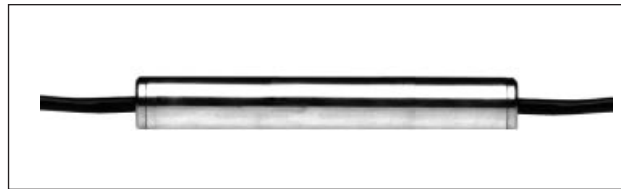

mitter should be located in a an environment no higher than 158°F (70°C) in temperature. Additional t/c extension wire may be added as required. Use of twisted shielded t/c wire is recommended (same as on the IRt/c and transmitter), and maintain shield connections.

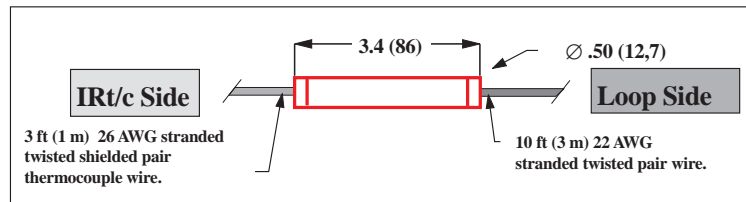

3. Check load on transmitter and power supply voltage for correct range (10 VDC minimum @ 10Ω; to 22 VDC minimum @ 1KΩ).
4. Set readout device (controller, computer, PLC, etc.) for 4 to 20 mA range to match the t/c.XMTR model range.
5. Perform final calibration of IRt/c installation in accordance with IRt/c instructions, using offset on current loop readout device.
6. Installation complete.

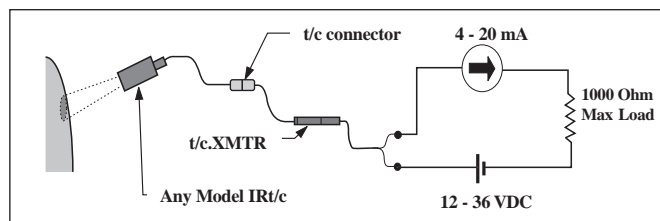

Model Numbers Example: t/c.XMTR-J-150	J150 K150	J500 K500	J1200 K1200	K2000	S3000
Temperature at 4 mA	32°F				
Temperature at 20 Ma	150°F (65°C)	500°F (260°C)	1000°F (540°C)	2000°F (1100°C)	3000°F (1650°C)

Easy Upgrade of Existing Temperature Control Systems with IRt/c and t/c.XMTR

- Replace conventional infrared sensing systems for superior accuracy, reliability, and low cost.
- Replace contact temperature sensors for non-contact measurement of actual product temperature instead of oven temperature.
- Retrofit using existing PLC analog inputs (4-20 mA, 0-5 V, 0-10 V).

The t/c.XMTR is specifically designed to make replacement or retrofit simple and inexpensive:

- In-line t/c.XMTR design is only slightly larger than the cable and requires no mechanical support.
- Precalibrated for thermocouple type and temperature range eliminates all adjustments, requirements for simulators, etc.

**For OEM's, IRt/c's and t/c.XMTR can be factory supplied wired together.*

- Hermetically sealed stainless steel construction is suitable for the harshest service without any additional packaging.
- Use any existing wiring, including thermocouple, RTD, etc.

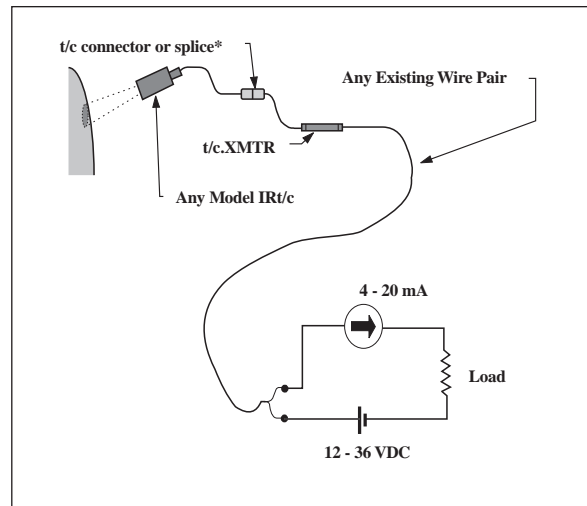

The t/c.XMTR is specifically designed to interface to any model IRt/c (or any conventional thermocouple) by a simple thermocouple connector or splice. The 2-wire current loop can be used in any conventional current loop, 0-5V, or 0-10V circuit that is scaled for the temperature range of interest.

Precalibrated Hi E and Lo E Models for OEM Applications

Add "PC" Suffix to Any Type K Adjustable Model

Non-adjustable IRt/c's are particularly attractive in applications where reproducibility and interchangeability are important, or where tamperproof sensors are desired. For low temperature applications, the many non-adjustable IRt/c models available provide the user with a wide selection to fit such needs. However, many higher temperature applications, with both high and low emissivity targets also require precalibrated non-adjustment features. In addition, for systems in which linearization software is employed in the readout device, the installation calibration can be performed more conveniently in software rather than making an adjustment on the IRt/c.

To take advantage of these models, the following is required:

1. Thermocouple input to programmable readout device (or 4-20 mA if transmitter is employed).
2. Signal output lookup table for either *HiE - PC* or *LoE - PC IRt/c models*.

The following models are available with the PC calibration designation, with the same signal output at all temperatures. The maximum recommended target temperature for all models is 2000°F (1100°C). The minimum recommended target temperature depends on the precision of the thermocouple input amplification system, but a reasonable lower limit is 700°F (370°C) for the HiE and 1000°F (540°C) for the LoE. For other specifications, refer to the Model Selection Chart or the individual model specification sheet.

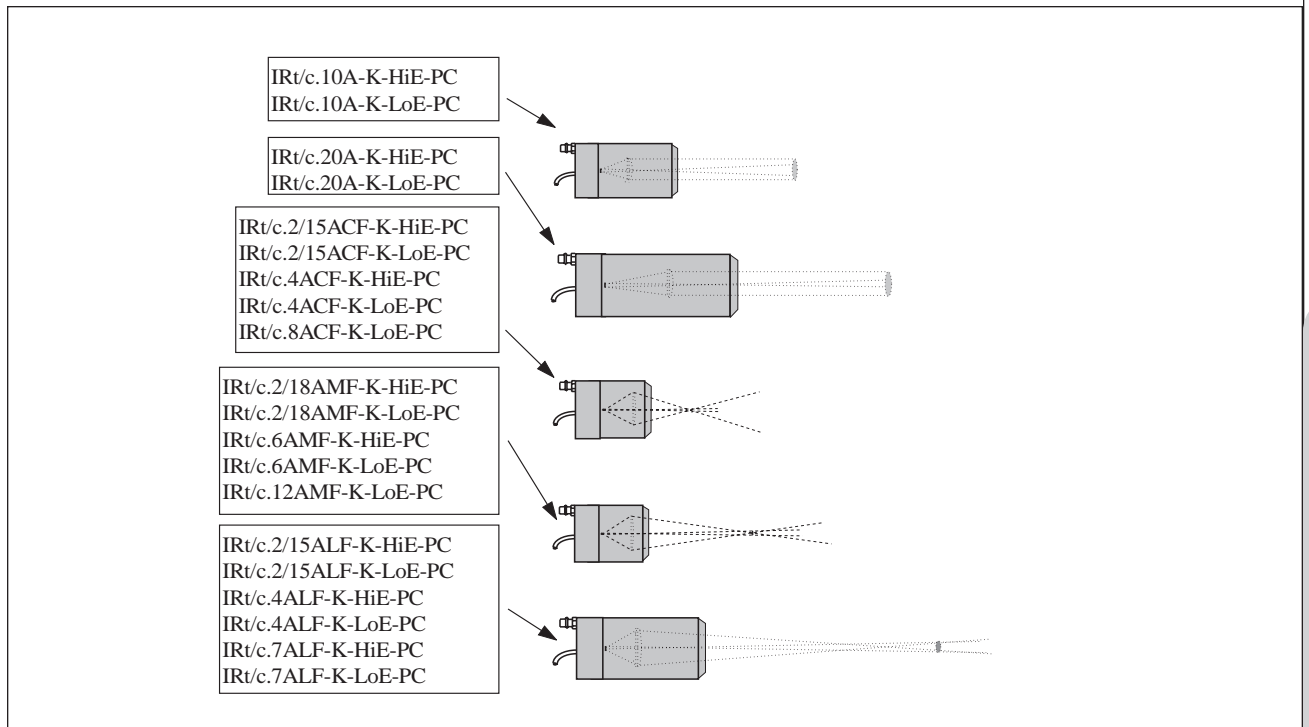

IRt/c™ Non-Contact Heat Sealing Temperature Control for Packaging Machinery (OEM & Retrofit)

IRt/c infrared thermocouples can accurately control the temperature of rotating and moving stainless steel heaters common in the packaging industry, without touching the heaters.

Typically, uncoated stainless steel heaters are difficult for IR sensors to measure reliably because of reflected infrared signals that can change after a heater surface is cleaned. The solution to this problem is simple:

Choose an unused location on the heaters, as close as possible to the surface you wish to measure. Mechanically mount a surface that is reliable for the IRt/c to measure.

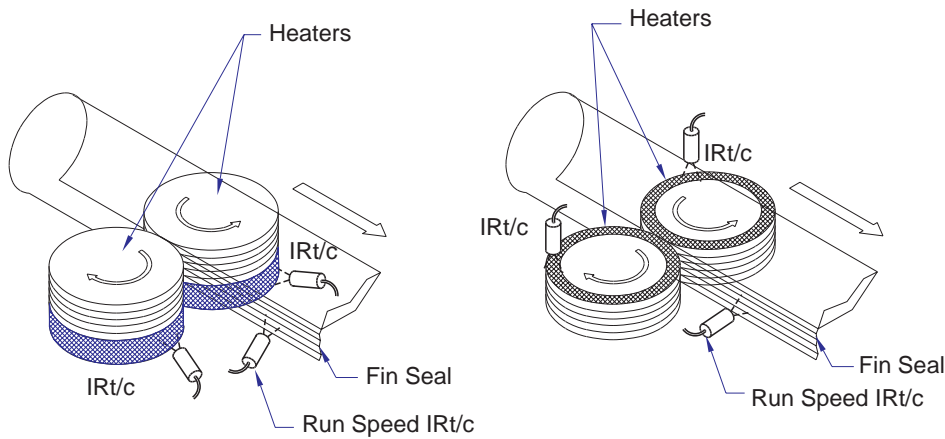

There are at least two choices for a reliable infrared target surface that meet the needs of the packaging industry (able to withstand repeated daily cleanings, durable to provide years of service):

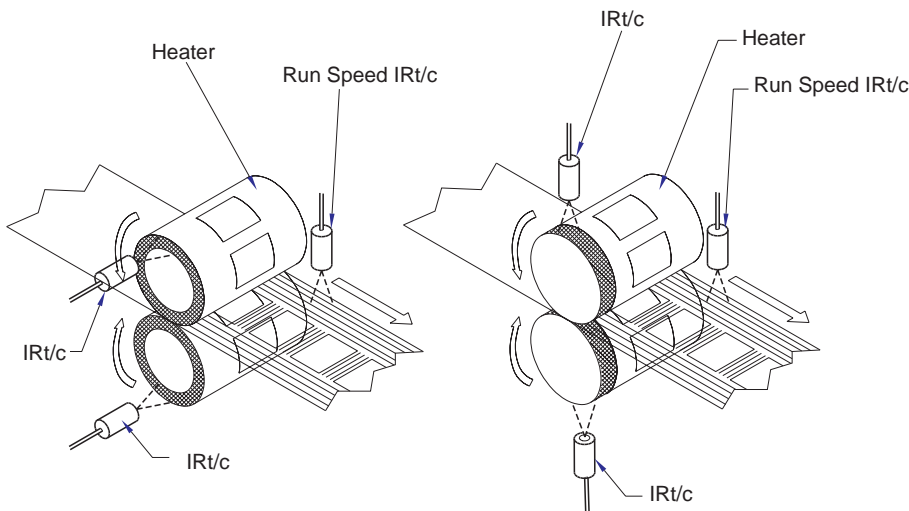

1. Black, hard-anodized aluminum coated surface

A black, hard-anodized aluminum hoop, ring, disk, or strip can be used. The surface must be “hard-anodized”. It can be mounted in place onto the steel heaters by using thermal epoxy, small screws, or other suitable mounting methods.

This method is very good for “retrofit” situations. The IR target surface can be added right onto existing heaters.

2. Teflon coating, directly applied onto an unused part of the stainless steel heaters

This is an excellent choice for OEMs that already use teflon coatings in other parts of their machines. Simply have a teflon coating added to the best target area prior to installing the heaters.

“Open and Close” Heaters/Cutters - IRt/c control

For jaw heaters/cutters that “open and close”, attach a small piece of coated metal to each heater head. This strip will come to the same temperature as the heater head as heat is conducted through the attachment point. The length of the strip should be just long enough so that the IRt/c sensor constantly looks at the strip during each “open and close” cycle giving a constant update of the temperature of the heaters.

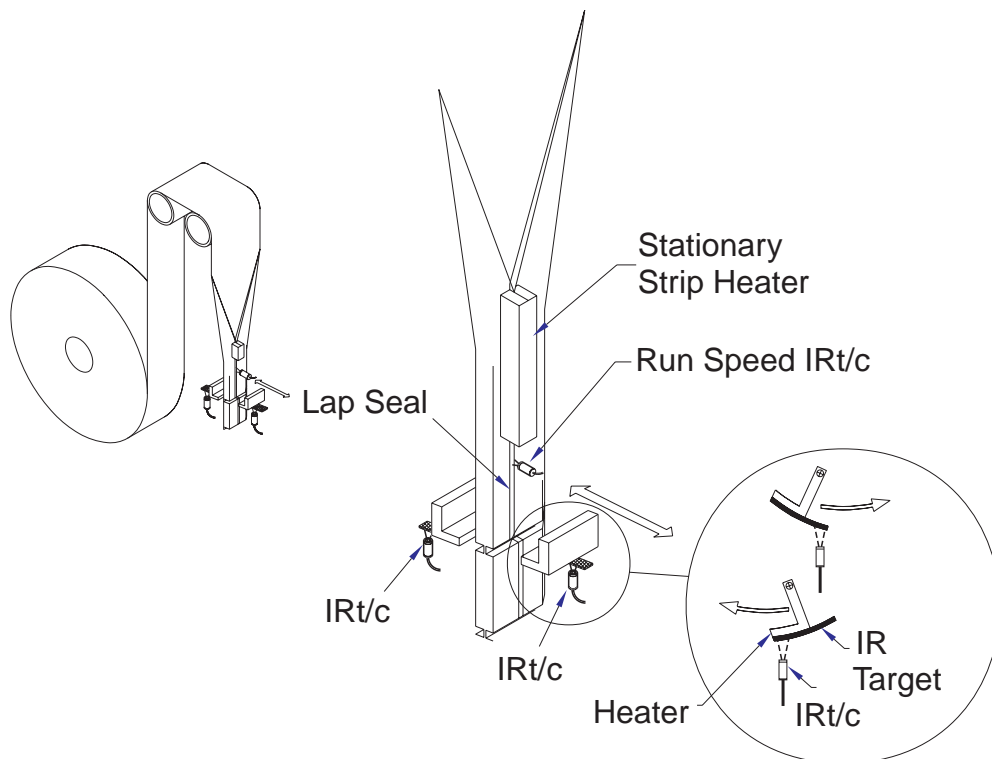

High Speed / High Performance Heat Sealing

For **Rotating Heaters** and for **Stationary Strip Heaters**, an additional IRt/c can be added to control the sealing much more accurately as the machine begins to increase speed. The technique is as follows:

1. During start-up, control the heaters using the sensors directly measuring the heaters.
2. As the machine speeds up, switch temperature measurement for the heater control system to a “**run speed IRt/c**”. This sensor is aimed directly at the actual fin seal, or lap seal, just after it is formed by the heaters. The “run speed IRt/c” will measure the actual seal temperature directly from the seal itself.

Explanation

By measuring the actual temperature of the seal during high speed running, the heater control can be very precise, on the order of a few degrees. This will allow very tight tolerance heat sealing. This system will automatically reduce the following possible sources of high speed heat seal error:

- Dirt build-up on the heater sealing surface that impedes heat transfer to the seal
- Packaging material changes in thickness
- Changes in pressure applied to the seal

The control accuracy of this type of high performance system can also allow the use of a wider variety of packaging material compositions on the same machine.

IRt/c's - Reliable, Durable

The rugged IRt/c sensors need no power supply, and are designed for years of trouble-free operation in industrial environments

No maintenance is required. The sealed IRt/c sensors can even be steam-cleaned.

For "dusty" packaging environments, we recommend using the IRt/c.3X or other IRt/c models with built-in air-purge system. With a small amount of air, the sensor window will remain clear.

With the Exergen IRtc2132 temperature controllers, even small packaging machines can now benefit from reliable IRt/c temperature control for thermal sealing of packaging.

If additional technical assistance is needed, please contact Exergen.

Web Drying - IRt/c's™ for Transparent & Reflective Films, Paper & Textiles (OEM & Retrofit)

By using IRt/c sensor technology, a dramatic increase in high quality output of web processing can be achieved.

- Increase drying speeds up to 20% or more
- Reduce scrap up to 75% or more
- Faster setup time when a new material is setup for processing
- Greater variety of web materials to be processed on the same machine

BACKGROUND

A common problem in high speed manufacturing of packaging films, paper and textiles, is dryer oven control for high speed drying of adhesives, inks and coatings onto the material.

With transparent films, IR sensors tend to “see” right through the film. And the amount of “see through” can vary with the thickness and composition of the film. With metallic films, IR sensors tend to see mostly reflections. These reflections can vary due to the surface condition and composition of the metallic component of the particular film. Measuring the true temperature of transparent and reflective films is extremely difficult, even with expensive IR sensors with special filtering. **Measuring the drying process, however, is easy with IRt/c sensors.**

HOW IT WORKS

The key to measuring the drying process of webs is to use multiple IRt/c sensors to get a relative temperature profile. Multiple IRt/c sensors installed in the dryer, allow you to control the drying process with the utmost precision.

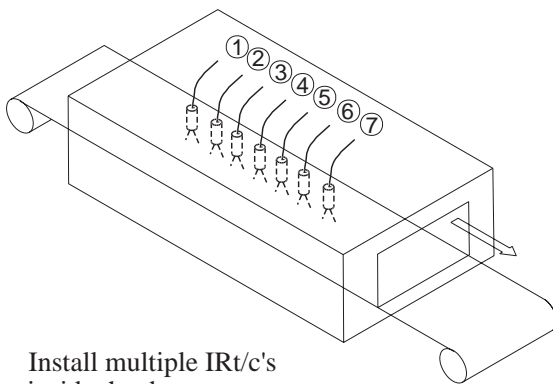

Install multiple IRt/c's inside the dryer.

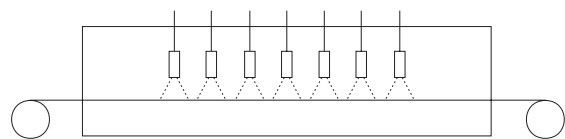

What the IRt/c's see: When a coating, even a thin coating, of glue, ink, or other finish is added to a surface, the coating itself becomes visible to IRt/c sensors. The drying characteristics of the coating can be seen even on reflective and transparent films. Even if it is a partial coating, the sensor can still “see” it. (The reason for this is that liquids, even very thin layers of liquids, are highly “emissive”, in other words they absorb and emit IR very well.)

Because the IRt/c can see this thin layer, it then becomes easy to use multiple sensors to graphically, or numerically, display a “trend” of what occurs on the surface of the web. It is this “trend” that is important in controlling the drying.

A trend plot of relative temperatures in a drying process will always show a lower relative temperature while the coating is drying. The heat energy of the oven, goes into evaporating the carrier of the coating, so the relative temperature indication by the IRt/c is “lower”.

As soon as the coating becomes dry, however, evaporation stops. The heat energy of the oven then goes into heating the coating and substrate. The relative temperature indication by the IRt/c becomes “higher”. These “lower” and “higher” relative temperature indications of the drying process by the IRt/c sensor are totally independent of the emissivity and transmissivity problems for “see through” and “reflective” films. Because of this, the relative temperature information of the IRt/c sensors can reliably be used for accurate drying control.

For opaque, non-metallic web materials such as paper and textiles, the IRt/c sensors will also display true web temperature along with the trends.

MANUAL WEB DRYING CONTROL

Install each IRt/c with an IRtc.2132 controller/display unit, or with an appropriate data acquisition display system, (or other means of display). No calibration is necessary for relative temperature data. The machine operator can then quickly observe the relative temperature trends shown by the IRt/c’s and decide if, and where, the web is being dried. To make a decision, the operator simply looks for the characteristic relative temperature change, **sensor to sensor**, to see where the evaporation process stops.

If the sensors show relatively little change, (**sensor to sensor**) all the way through the oven, then the web isn’t being dried (i.e. evaporation isn’t complete).

If the sensors show a steady increase in web temperature from the first sensor position, then the coating is missing, or, is drying so fast that overdrying occurs (and wasting energy!).

Using the sensor display information, the operator can then manually adjust the dryer controls so that the web dryout point is both moved to, and maintained within, the desired location inside the dryer. Manual adjustments based on our sensor display information allow the user to maximize production efforts while minimizing energy costs.

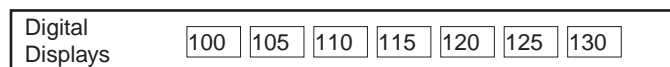
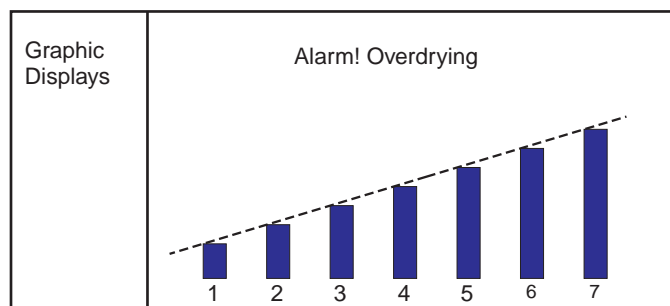
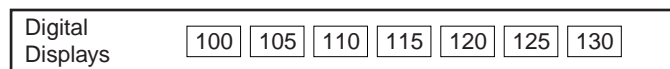
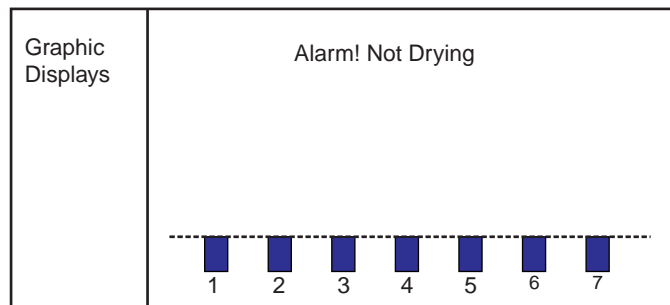
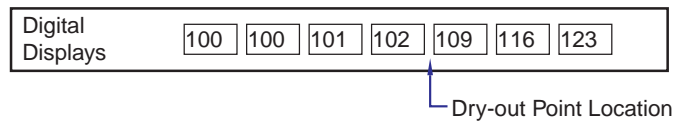
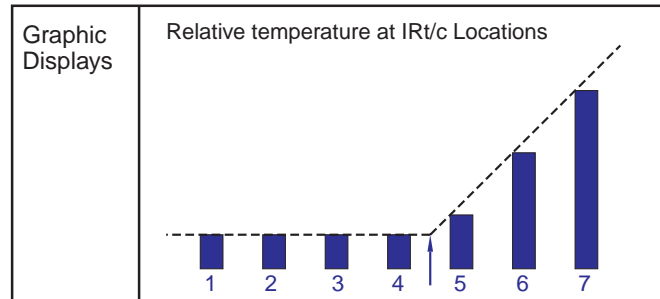

AUTOMATIC WEB DRYING CONTROL

Install the IRt/c sensors and connect to a PLC or industrial computer. No calibration is necessary for relative temperature data. Write a short program to calculate the temperature difference from sensor to sensor in this way:

$((T3-T2)-(T2-T1))$, $((T4-T3)-(T3-T2))$, $((T5-T4)-(T4-T3))$, etc. These calculations represent the change in "slope" from sensor-to-sensor for relative temperatures of each sensor.

The maximum value found for $((T3-T2)-(T2-T1))$, $((T4-T3)-(T3-T2))$, $((T5-T4)-(T4-T3))$, etc., tells precisely where the "dryout point" of the web is occurring in the oven.

With some quick tests on actual product, the program can be further refined to fit the drying profiles more precisely, such as setting a minimum or maximum value for the changes in slope for startup conditions, high speed, etc.

INSTALLATION GUIDELINES

1. Select enough sensors to give relative temperature indication over the length of the oven. For maximum control of long ovens, we recommend at least one sensor every 20 inches (0.5 meters). For compact, high speed drying ovens where control has to be very precise because drying must occur within a very short distance on the web, we recommend sensors be spaced about every 6 inches (15 cm), or less.
2. We recommend that the sensors be installed right inside the oven, if possible, as close as possible to the web. By mounting sensors close to the target web, other minor sources of IR errors are minimized. (IRt/c sensors can be installed inside drying ovens up to 750 F (450 C) with air cooling alone.) We recommend using the IRt/c.3X model for web drying.

If this is not possible, IRt/c's can be installed outside the oven, looking through a sight tube at the web. Select an IRt/c model with a field of view that can look down the sight tube at the web.

3. For internal oven air drying temperatures up to 212 F (100 C), the sensors can be installed inside the oven with no air cooling. Select the IRt/c.3X (or IRt/c.3SV for tight spaces) sensors and use the built-in air purges to keep the sensor window clean for zero maintenance.
4. For internal oven air drying temperatures above 212 F (100 C) select the IRt/c.3X sensor with the CJK-2 (air cooling jacket kit). This combination will allow the sensor to be kept clean and cool in up to 750 F (450 C) drying ovens with air only.

IRt/c's - RELIABLE, DURABLE

The rugged IRt/c sensors need no power supply, no periodic calibration, and are designed for years of trouble-free operation with all types of dryer ovens. For additional technical assistance, please contact Exergen.

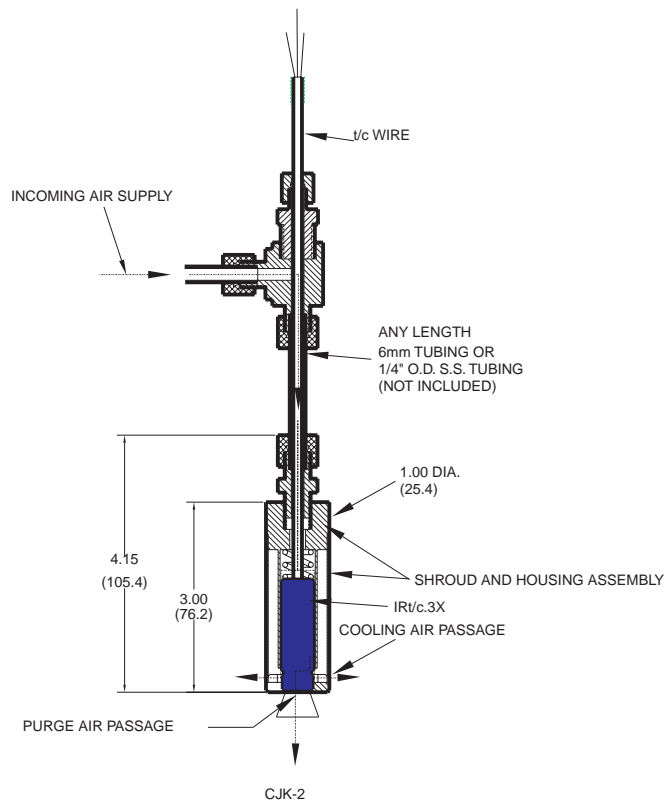

IRt/c's™ -- Use With Heated Metal Rollers / Web Processes To Increase Production (OEM & Retrofit)

By using IRt/c sensor technology, a dramatic increase in high quality output of web processing can be achieved. Use the IRt/c's with chrome-plated, stainless steel, or other uncoated metal rollers as well as with coated rollers. IRt/c systems enable the user to:

- Increase throughput speeds up to 20%, or more, on the same machine
- Reduce scrap up to 75% or more
- Shorten set-up times
- Process a greater variety of web materials on the same machine

Applications / Processes that would benefit from the use of IRt/c technology:

- Textile Processing
- Paper Processing
- Opaque Films Processing
- Any continuous web processes using heated (or cooled) rollers

Use of Exergen's unique patented, non-contact infrared sensors solves past technical difficulties associated with temperature measurement of shiny, uncoated metal rollers (due to the high infrared reflectivity of the uncoated metal surfaces). Exergen has developed and tested a **two stage approach** to accurately measure and control the heat output of heated (or cooled) metal rollers using our IRt/c's—even at very high speeds.

Stage 1: START-UP and STAND-BY Temperature Control

During start-up and stand-by conditions, the temperature of the heated roller will become fairly uniform throughout the roller surfaces. Because of this, the temperature can be reliably measured at any convenient location on the surface, or the edge, of the rollers.

So, for **Stage 1**, simply install an IRt/c so that it can see a reliable signal from the roller.

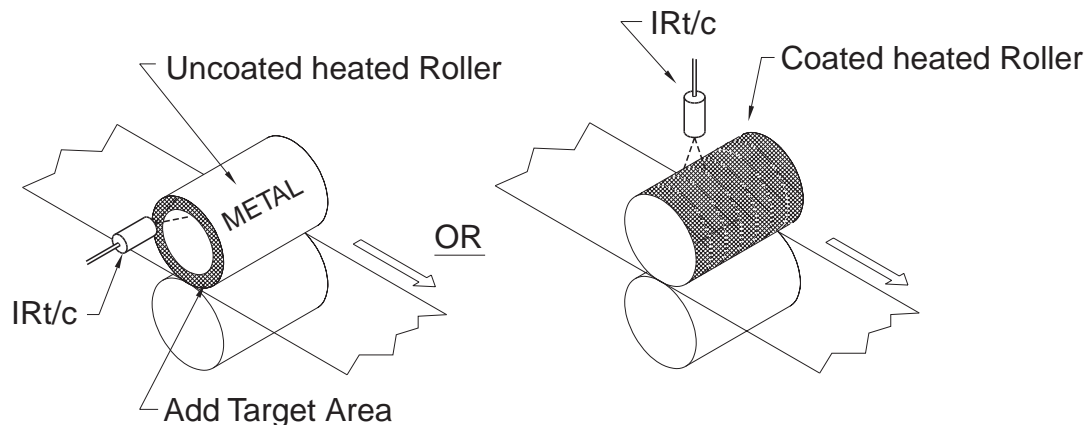

Stage 1: Start-up, Stand-by

UNCOATED METAL ROLLERS

On an unused edge of the roller, install a durable non-metallic target surface finish. This can be done with:

- (a) a durable epoxy paint
- (b) the addition of a thin metallic hoop, or ring, with a Teflon coating
- (c) or the addition of a thin hoop, or ring, of black, hard-anodized aluminum.

Install an IRt/c sensor so that it looks at this coated surface. Use this sensor to control the temperature of the roller during start-up and stand-by modes

COATED METAL ROLLERS (silicon coating, Teflon, any non-metallic coating, etc.)

Install an IRt/c to aim at the center, or any convenient location, on the surface of the roller.

Stage 2: RUNNING Temperature Control

For **Stage 2**, install an additional IRt/c sensor to look directly at the web surface after it contacts the heated roller. **As the web begins to move, (or, at a preset rpm) the temperature control system for the roller should be switched over to a control system connected to this IRt/c sensor.**

This IRt/c sensor should be mounted so that it looks at the side of the web material that is heated by the roller. For webs heated on two sides, sensors should be mounted on each side to control each heated roller.

For wide webs: multiple IRt/c sensors can be installed across the web.

For multi-zone rollers: use at least one IRt/c for each zone across the web.

Explanation

The most common errors in web processing are as follows:

Temperature Measurement Errors - errors due to incorrect temperature measurement.

- Thermocouple "Slip ring" signal errors
- Internal temperature sensor location errors

Heat Transfer Errors - errors caused by variations of heat transfer to the web.

- Web material changes in thickness, moisture content, etc.
- Dirt build-up on the heater roller surface that can impede heat transfer to the web
- Changes in pressure applied to the web as it contacts the heated roller

As the roller speeds up, heat is removed from the roller surface by the web material. Temperature gradients appear inside the roller, and on the roller surface. Conventional embedded, surface, or edge temperature sensors cannot adequately track and compensate for all these temperature variations, nor can they adequately measure the amount of heat transferred to the web material.

Exergen's **Two Stage IRt/c Sensor & Control System** automatically reduces all these sources of web temperature processing errors. Thus, the actual temperature of the webs can be both tightly (to within a few degrees) and consistently controlled through the use of IRt/c sensor technology.

The rugged IRt/c sensors need no power supply, no periodic calibration, and are designed for years of trouble-free operation. For additional technical assistance, please contact Exergen.

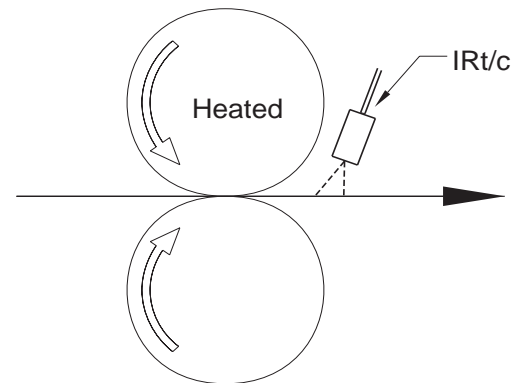

Stage 2: Running

IRt/c™ Heat Balance Series for Medical Applications

The Heat Balance (HB) Series of IRt/c infrared thermocouples have the ability to measure the **internal temperature** of the target material, **non-invasively**, by employing a patented heat balance technique. A typical application in medical equipment is monitoring or controlling the temperature of fluid transported through disposable tubing when warming or cooling:

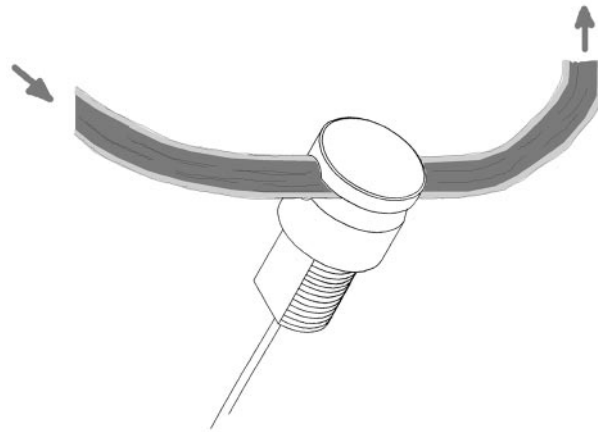

- Transfusion systems
- IV warming systems
- Dialysis systems
- Cardio-pulmonary bypass systems
- ECMO systems
- Blood analyzers

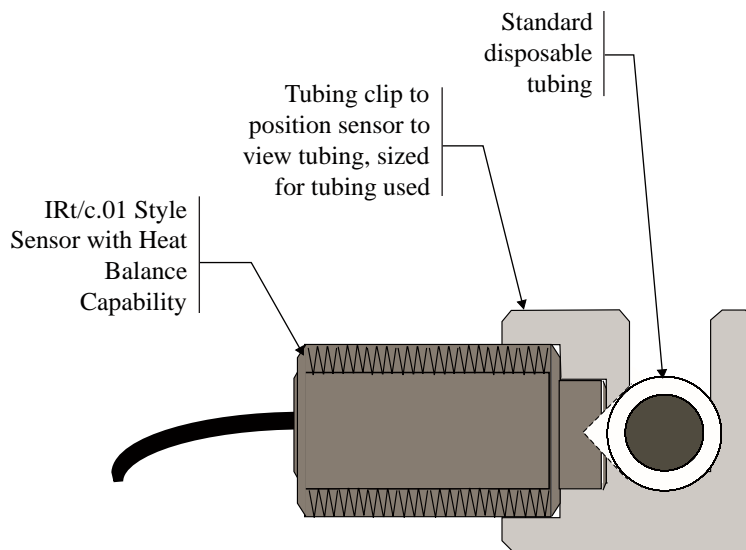

The IRt/c.01HB model pictured, actually measures the internal fluid temperature by measuring both tubing surface and ambient temperatures then calculating the internal temperature necessary to maintain the heat balance. A convenient clip head provides a reproducible mounting location for the sensor and can be quickly attached to new tubing and removed from used tubing.

Principles of Operation

Fluid at temperature T_f flowing in tubing transfers heat via convection through thermal resistance R_f to the tubing inside surface, which in turn conducts heat to the tubing external surface through thermal resistance R_t , which then transfers to the environment via radiation and convection thermal resistance R_o . The temperatures of the wetted surface of the tubing, outside surface of the tubing, and the local ambient are given by T_w , T_s , and T_a , respectively.

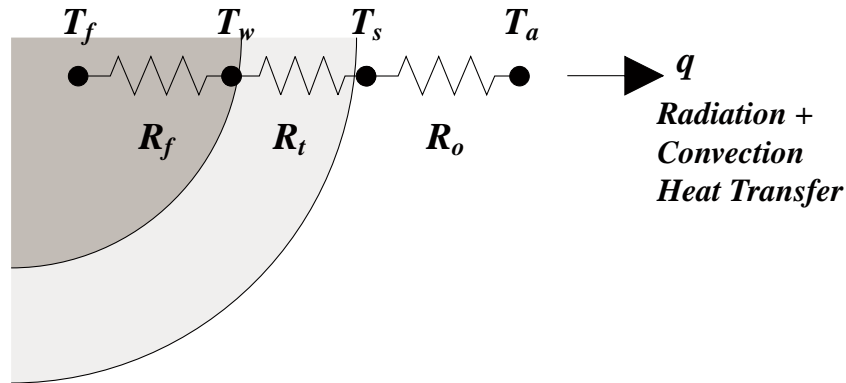

Employing the method of thermal analysis with electrical analogs: current = heat flow, and voltage = temperature, the heat transfer equation may be written as follows:

$$q = \frac{1}{R_f + R_t + R_o} (T_f - T_a)$$

and via heat balance:

$$= \frac{1}{R_o} (T_s - T_a)$$

Accordingly,

$$T_f = \frac{R_f + R_t + R_o}{R_o} (T_s - T_a) + T_a$$

The IRt/c-HB Series measures both T_s and T_a , and solves this equation automatically for fluid temperature T_f , providing a highly accurate method of monitoring or controlling the temperature of interest.

The configuration shown above is the model IRt/c.01HB-J-37C with its convenient tubing clip. Any of the IRt/c models can be configured for the HB calculation. Contact the factory for further details.