

IR t/c™ Infrared Thermocouple Accessory

IR t/c™ COOLING JACKET KIT ASSEMBLY INSTRUCTIONS

IR t/c™ Cooling Jacket Kit

The IR t/c™ Cooling Jacket allows our infrared thermocouples to be used in a very wide range of applications. The jacket is physically small, has durable stainless steel construction, and a super efficient cooling design. The Cooling Jacket Kit can be used with both the IR t/c and the IR t/c.2 The kit allows for either air-cooling or water-cooling of the sensor body, and air purge to keep the sensor window clean.

- Features**
- Small size 1" dia x 4.16" length (25mm x 106mm)
 - Stainless steel housing
 - Air cooling
 - Water cooling
 - Air purge
 - Super efficient design
 - Very low water and/or air usage
 - Fits both IR t/c and IR t/c.2

- Benefits**
- Air only cooling in 450°F (230°C) ambient with 1 cfm (28 liters/min)
 - Water cooling in 1000°F (540°C) ambient with as little as 0.05 gpm (190 cc/min)
 - Allows sensor to be positioned close to target surfaces for best accuracy and repeatability
 - Enhances IR t/c performance outside linear range

IR t/c™ Sensor Body Cooling Guide Surrounding Temperatures

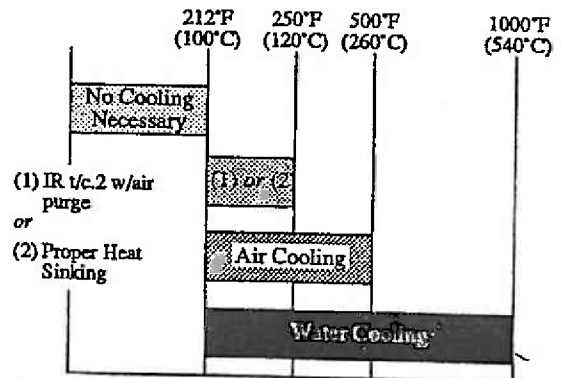

EXERGEN

**IR t/c™
Infrared
Thermocouple
Accessory**

AIR COOLING ASSEMBLY

1. See Figure 1. Unscrew the stainless steel Shroud and remove the copper Water Coil from the Housing. (Straighten and push the copper tubing forward to remove.)
2. Locate the Steel Spring supplied in the kit. Slide the spring over the end of the thermocouple cable.
3. Slide the end of the thermocouple cable through the Housing as shown in Figure 1.
4. Screw the Shroud onto the Housing.
5. Install the Air Fitting B4 as shown in Figure 4 and 4A.
6. Install the Set Screw as shown in Figure 4 and 4A. (IMPORTANT. This must be installed to route air flow properly through the cooling assembly. The opening should not be used for exhaust air unless you use the center hole with the thermocouple wire as an intake port.)

The infrared thermocouple cable is teflon sheathed and is rated for 500°F (260°C) ambient.

7. **OPTIONAL** To route exhaust air out of your process and/or provide cooling air to the thermocouple cabling, use the Male Connector fitting as shown in Figure 3. Install the appropriate length of copper (or steel) tubing over the cable De-burr the end of the tube. Make certain that there is enough clearance between the thermocouple cable and the inner diameter of the tube for the low airflow required. Check for airflow after tightening the tube into the fitting.

Assembly complete.

AIR COOLING INSTALLATION SUGGESTIONS

- Use relatively clean air. Oily, dirty air can "fog" the sensor window. Install a proper air filter if necessary
- Supply approximately 1 cubic foot per minute (28 liters per minute) air flow, 5psi (0.35 bar), for ambients at 450°F (230°C). Increase or decrease flow accordingly for higher or lower ambients.
- Increase air flow and insulate all connector tubing if your installation requires long air supply and exhaust extensions exposed to the high temperature ambients.

EXERGEN

**IR t/c™
Infrared
Thermocouple
Accessory**

AIR COOLING ARRANGEMENT

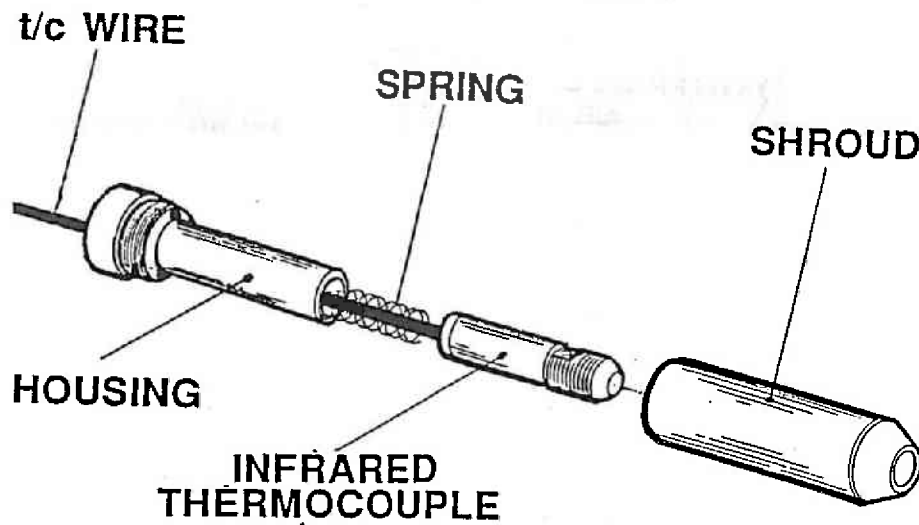

FIG.1

WATER COOLING ARRANGEMENT

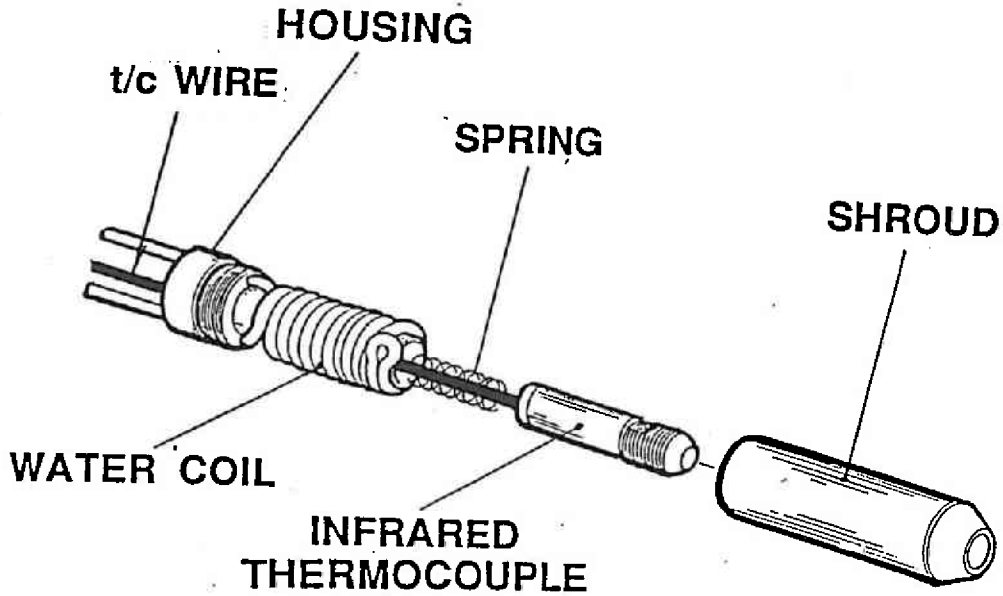

FIG.2

EXERGEN

IR t/c™ Infrared Thermocouple Accessory

AIR COOLING CONFIGURATION

SEE FIG.1 FOR
THERMOCOUPLE ARRANGEMENT.

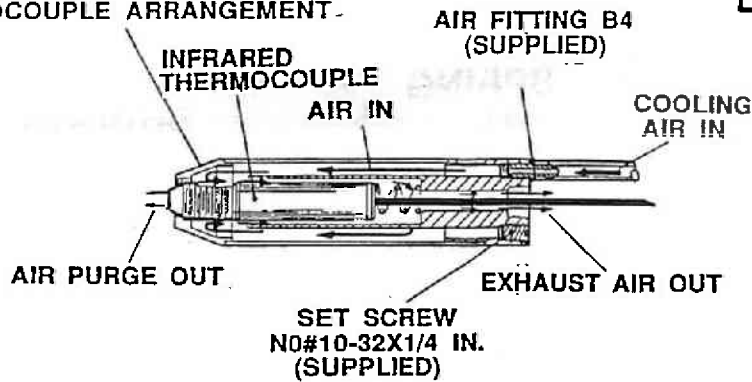

FIG.4

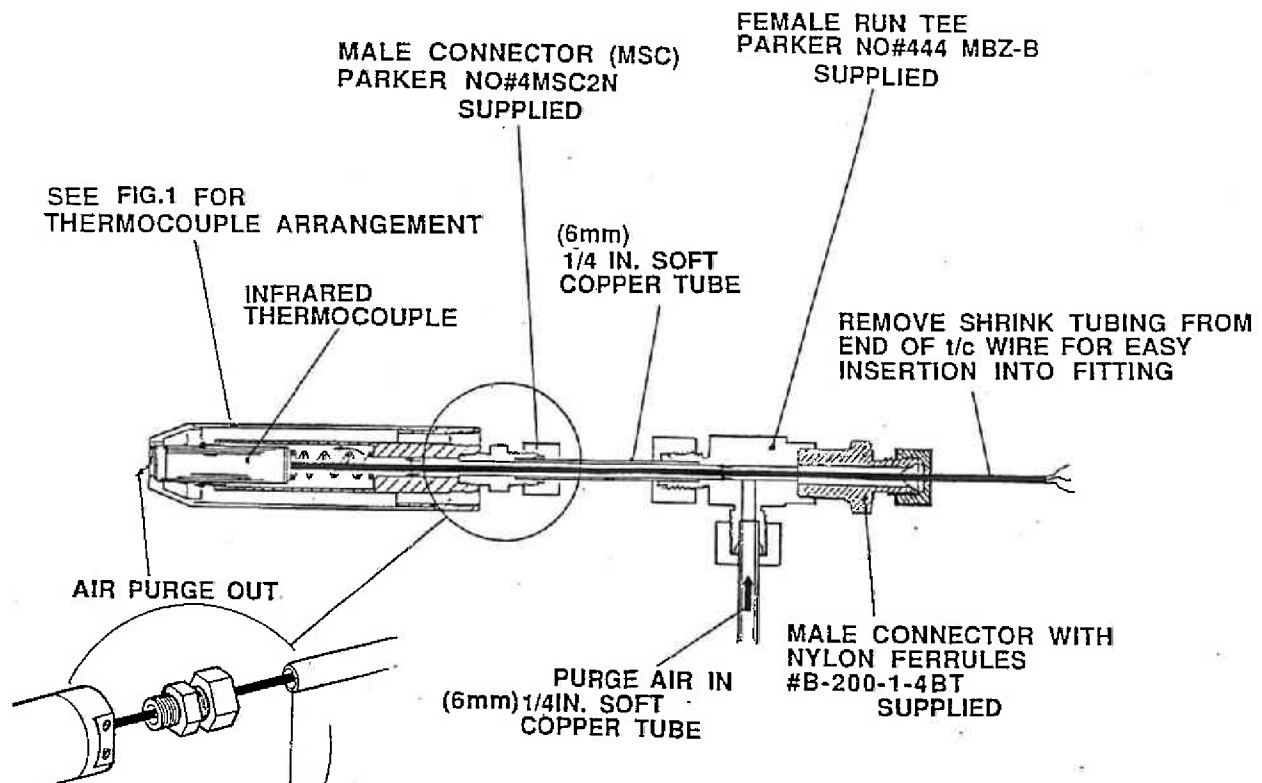

FIG.3

MAKE CERTAIN THERE IS AMPLE CLEARANCE BETWEEN 1/c WIRE AND ID OF COPPER TUBE. CHECK AIR FLOW AFTER TIGHTENING MSC ONTO TUBE. TRIM END OF TUBE (ID) FOR PROPER AIR FLOW.

EXERGEN

IR t/c™ Infrared Thermocouple Accessory

WATER COOLING ASSEMBLY

1. See Figure 2. Unscrew the stainless steel Shroud from the Housing.
2. Locate the Steel Spring supplied in the kit. Slide the spring over the end of the thermocouple cable.
3. Slide the end of the thermocouple cable through the Housing as shown in Figure 2.
4. Screw the Shroud onto the Housing. Water Cooling Assembly is complete.
5. **AIR PURGE REQUIRED - IMPORTANT - Please read!** Air purge is required with water cooling for all installations, except in environments that are very "dry", or inside a vacuum. The reason is as follows: when the sensor is cooled to a temperature lower than the surrounding air (which always occurs when water cooling is used) any gases with condensation temperatures below 212°F(100°C) will condense on the sensor window and "fog" it. This can decrease accuracy of the sensor.

The easiest way to prevent condensation on the sensor window is to utilize the air purge. A small amount of clean, normally dry air is sufficient for most applications. Maintain enough airflow to keep the sensor window clean.

For Air Purge - Install the Male Connector (MSC) fitting as shown in Figure 3. Install the appropriate length of copper (or steel) tubing over the cable. De-burr the end of the tube. Make certain that there is enough clearance between the thermocouple cable and the inner diameter of the tube for the low airflow required. Check for airflow after tightening the fitting.

Install a suitable TEE fitting to split thermocouple cable route and air supply route as shown in Figure 3. Install a suitable sealing fitting to seal the exit point for the thermocouple cable. A suitable part is described in Figure 3

WATER COOLING INSTALLATION SUGGESTIONS

- Use relatively clean air for air purging. Oily, dirty air can "fog" the sensor window. Install a proper air filter if necessary.
- **IMPORTANT** The use of a "de-ionizing filter" is strongly recommended to reduce the possibility of "scale build-up" in the copper water coil. Install a filter if your water supply is not already de-ionized.
- Supply approximately .05 gallons per minute (190 cc per minute) water flow for ambients at 1000°F (540°C). Increase or decrease flow accordingly for higher or lower ambients.
- Increase water flow and insulate all connector tubing if your installation requires long water and air supply extensions exposed to the high temperature ambients.

EXERGEN

IR t/c™
Infrared
Thermocouple
Accessory

COOLING JACKET KIT PARTS

- | | |
|---------------------------------|---|
| 831011 Air Fitting B4-NP | 820089 Set Screw, 10-32 x .18" |
| 833041 Housing, stainless steel | 831012 Male Connector, MSC |
| 833042 Shroud, stainless steel | 820087 Spring, steel |
| 837053 Water Coil, copper | 820088 Pan Head Slotted Screw, 6-32 x .5" |
| 831015 MALE CONNECTOR | |
| 831014 FEMALE RUN TEE | |

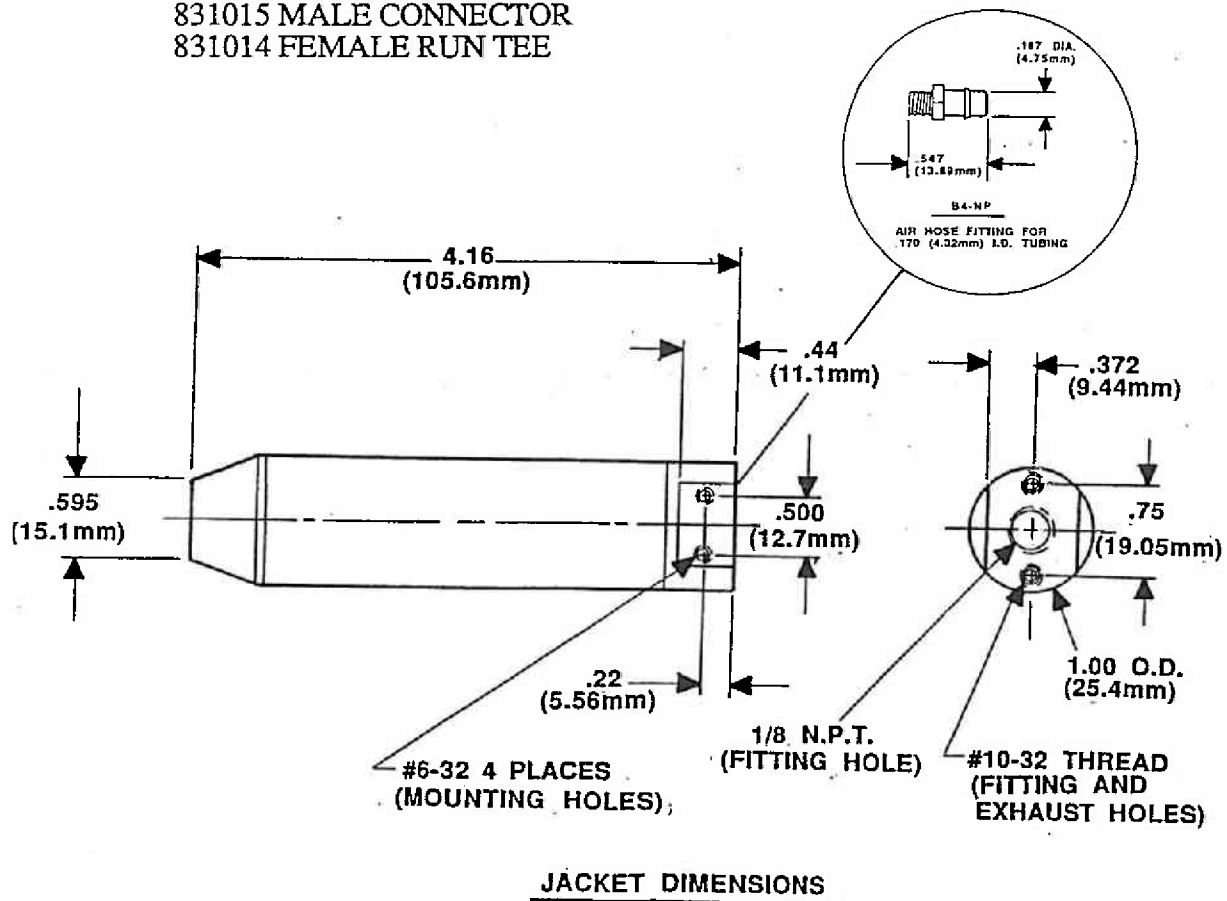

EXERGEN

IR t/c™ Infrared Thermocouple Accessory

WATER COOLING CONFIGURATION (WITH AIR PURGE)

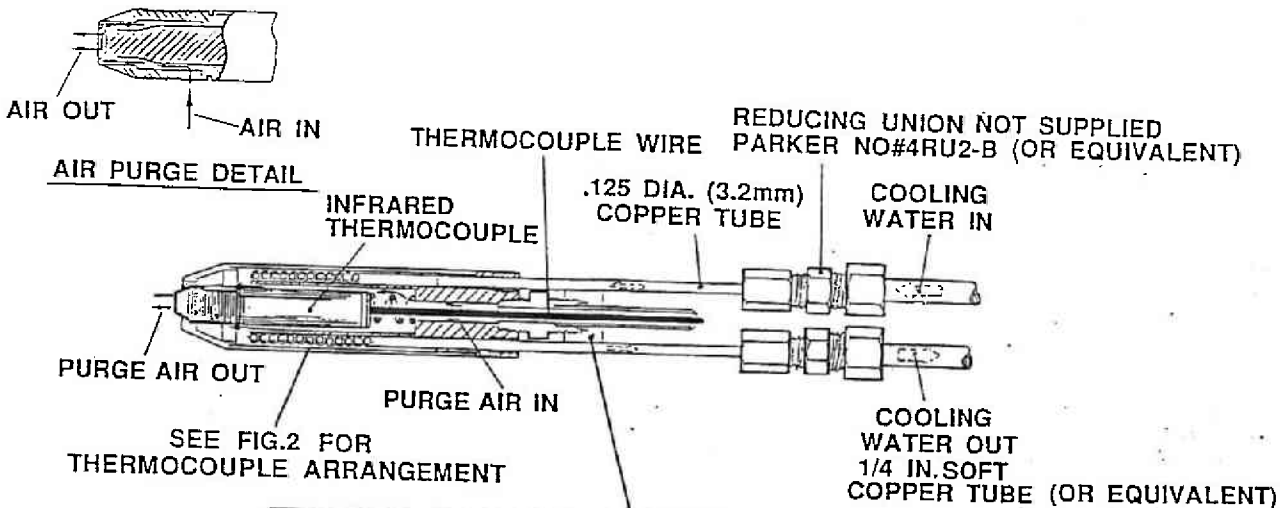

SEE FIG.3 & FIG.5A FOR ADDITIONAL FITTINGS REQ'D
NOTE; INSTALL AIR PURGE FITTINGS BEFORE
INSTALLING WATER FITTINGS

FIG.5

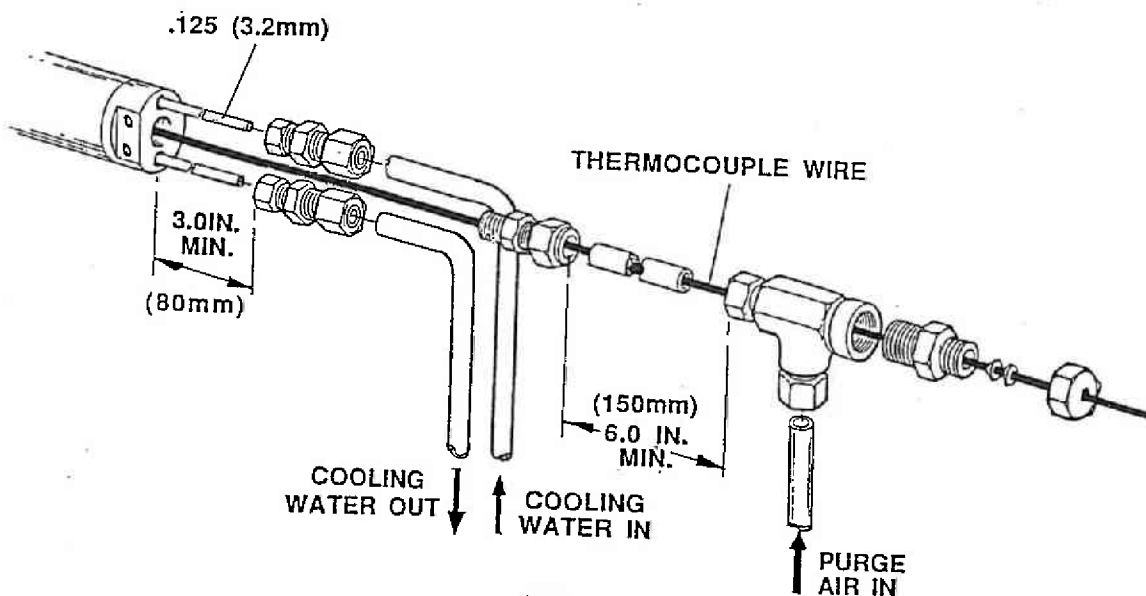

FIG.5A

EXERGEN

